

Teddington Engineered Solutions

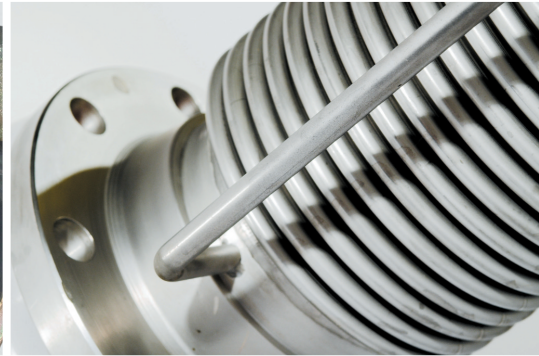

Expansion Joints

Product Catalogue



Precision Engineering

The Global Force in
Precision Engineering

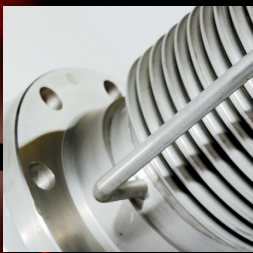

Product & Service Overview

Metallic bellows/expansion joints

Rubber bellows

Fabric bellows

Metallic hoses

PTFE bellows

CNC precision machining

Fabrication services

NDT services

Engineering design services

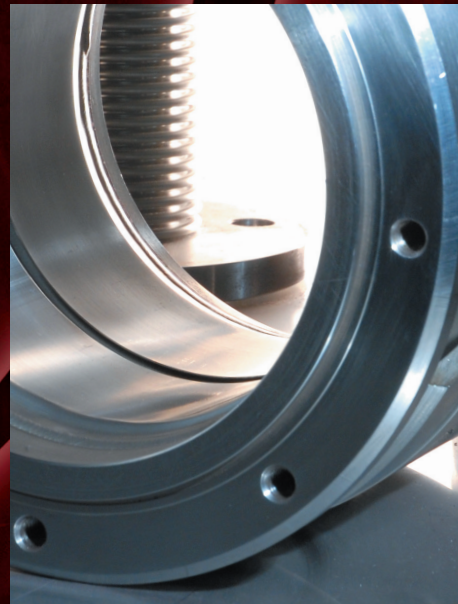

Rubber Expansion Joints



DN	YELLOW BAND ■					RED BAND ■					CR ■			ERP ●		
32	130		160				130		160				130			130
40	130		160				130		160				130			130
50	130	150	160				130	150	160				130			130
65	130	150	160				130	150	160				130			130
80	130	150	160				130	150	160				130			130
100	130	150	160				130	150	160				130			130
125	130	150	160				130	150	160				130			130
150	130	150	160				130	150	160				130			130
200	130	150	160	175			130	150	160	175			130			
250	130			175	200		130			175	200		130			
300	130				200		130				200		130			
350					200						200			200		
400					200						200			200		
500					200						200			200		
600					200						200			200		
700						275						275			275	
800					250						250			250		
900							300						300			300
1000							300						300			300

Available Teddington ERV Rubber Expansion Joints: Types and Lengths

DN	ROTEX =					YELLOW STEEL	GREEN BAND ■			WHITE BAND □			Orange Band ■	
32	130					130	130				130			130
40	130					130	130				130			130
50	130	160				130	130				130			130
65	130	160				130	130				130			130
80	130	150	160			130	150	130	150		130			130
100	130	150	160			130	150	130	150		130			130
125	130	150	160			130	150	130	150		130			
150	130	150	160			130	150	130	150		130			
200	130	150	160	175		130		130	150	175		130	175	
250	130			175	200	130		130		175	200	130	175	
300	130				200	130		130			200	130		
350					200						200		200	
400					200						200		200	
500					200						200		200	
600					200						200		200	
700						275						275		275
800					250							250		250
900							300							
1000							300							

Available Teddington ERV Rubber Expansion Joints: Types and Lengths

Rubber Expansion Joints

Properties and Applications of the Standard Rubber Lines for Teddington ERV Rubber Expansion Joints

TEDDINGTON Type	Rubber Type	Trade Name of Rubber Type	Applications
ERV - G (Yellow Band)	NBR	Nitrile	Petroleum based products, high octane fuels up to 50% aromatics & methanol content, cooling water with oily anti-corrosion additives
ERV - OR (Orange Band)	NBR	Nitrile	Reinforced type of YELLOW BAND for propane and butane, 20 bar max. working pressure
ERV - R/ERP (Red Band/Red Spot)	Butyl / EPDM Compound	Nitrile	Drinking water, cold and warm waste water, cooling water with non-oily additives, seawater, various acids and alkalis, salt solutions, technical alcohols, limestone and calcium sulphate suspensions
ERV - ROTEX (ROTEX)	EPDM	Buna AP / Keltan	Hot water (10 bar -100°C, 6 bar -110°C, temporarily Vistalon up to 130°C), cooling water with non-oily additives, hot air
ERV - GR (Green Band)	CSM	Hypalon	Aggressive acids, alkalis and chemicals up to 80°C
ERV - W (White Band)	Nitrile caoutchouc		Vegetable oils and other foodstuffs requiring a sanitary rubber compound, special silo applications
ERV - CR (Black)	Chloroprene	Neoprene, Baypren	Cold and warm water, swimming pool water, waste water, washing water, sea water, weak sour or alkaline water, cooling water
ERV - GS (Yellow Steel)	NBR with steel cord reinforcement	Nitrile	Motor connections, lubricating oil, hydraulic oil up to 100°C, flame resistant (suitable for ship engine rooms acc. Germanischer Lloyd, Lloyds Register, DNV, Nippon Kyokai)
ERV - TA (Teflon® lining for all types)	PTFE lining	Teflon®	All kinds of fluids in use

Yellow Band Expansion Joints with Steel Flanges

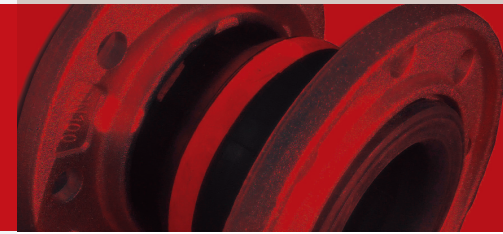

Weight App	Effect Area	Bellow Size DN		Press Nom.	Flange (1) Measurements mm			Length BL	Part Number
		in.	mm		D	kø	l x ø		
kg	Q:cm ²			bar				mm	Type
1.5	15	1"	25	16	115	85	4x14	130	ERV-G 25.16 ²
2.5	15	1 1/4"	32	16	140	100	4x18	130	ERV-G 32.16
2.7								160	ERV-G 32x160.16
3.0	20	1 1/2"	40	16	150	110	4x18	130	ERV-G 40.16
3.2								160	ERV-G 40x160.16
4.0								130	ERV-G 50.16
4.1	30	2"	50	16	165	125	4x18	150	ERV-G 50x160.16
4.2								160	ERV-G 50x160.16
4.5								130	ERV-G 65.16
4.6	50	2 1/2"	65	16	185	145	4x18	150	ERV-G 65x150.16
4.7								160	ERV-G 65x160.16
5.5								130	ERV-G 80.16
5.6	85	3"	80	16	200	160	8x18	150	ERV-G 80x150.16
5.7								160	ERV-G 80x160.16
7.0								130	ERV-G 100.16
7.1	125	4"	100	16	220	180	8x18	150	ERV-G 100x150.16
7.2								160	ERV-G 100x160.10
8.5								130	ERV-G 125.16
8.6	185	5"	125	16	250	210	8x18	150	ERV-G 125x150.16
8.7								160	ERV-G 125x150.16
11.0								130	ERV-G 150.16
11.1	250	6"	150	16	285	240	8x22	150	ERV-G 50x150.16
11.2								160	ERV-G 50x160.16
17.0								130	ERV-G 200.10
17.1	400	8"	200	10	340	295	8x22	150	ERV-G 200x150.10
17.2								160	ERV-G 200x160.10
17.3								175	ERV-G 200x175.10
23.5								130	ERV-G 250.10
23.8	600	10"	250	10	395	350	12x22	175	ERV-G 250x175.10
24.0								200	ERV-G 250x200.10
27.0	800	12"	300	10	445	400	12x22	130	ERV-G 300.10
27.5								200	ERV-G 300x200.10
39.5	1000	14"	350	10	505	460	16x22	200	ERV-G 350.10
42.0	1375	16"	400	10	565	515	16x26	200	ERV-G 400.10
59.5	2185	20"	500	10	670	620	20x26	200	ERV-G 500.10
70.0	3080	24"	600	10	780	725	20x30	200	ERV-G 600.10
135.00	4800	28"	700	10	895	840	24x30	275	ERV-G 700.10
125.0	5440	32"	800	10	1015	950	24x33	250	ERV-G 800.10
205.0	7100	36"	900	10	1115	1050	28x33	300	ERV-G 900.10
245.0	8700	40"	1000	10	1230	1160	28x36	300	ERV-G 1000.10

Type ERV - Yellow Band

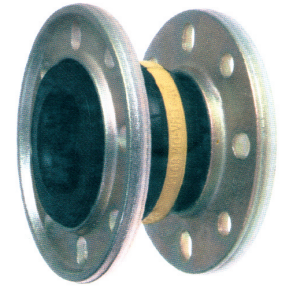

YELLOW BAND expansion joints in High-Tech design with steel swivel flanges with smooth holes for bolts, suitable for petroleum based products, DIN-fuels, also town gas and natural gas, except for LP gas. Suitable for cooling water emulsions with corrosion preventing oil up to 90° Celsius. Working pressure as per chart up to 16 bar. - Allowable vacuum see page 1-12.

Lining: NBR (nitrile), seamless, electrically conductive

Reinforcement: Nylon textile cord, NBR rubberized, warmth stabilised

Cover: Chloroprene CR, electrical conductive 103 - 106 Ohm

Stamping: Yellow band, ERV.size DN...PN 16, production date

Flanges: swivelling, carbon steel, zinc plated and yellow chromated

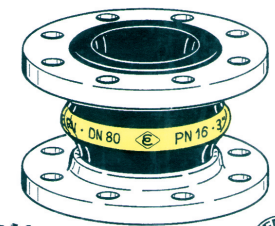

Approved for German military purpose

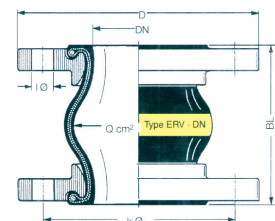

- 1) Other flange standards and materials available on request, for example DIN PN 6, 25/40, ANSI B 16.5 (ASA 150 lbs.), BS 10 table E, F, H. Flanges of stainless steel 1.4571, brass or hot galvanized steel.
- 2) For ELAFILBC Expansion Joints ERV-G 25.16 bellows DN 32 are used.

Allowable Movement for ERV- Yellow Band

Length		Recommended Installation Length		Available Range of Movement in Service				
BL	Tolerance	EL minimal	EL maximum	L minimal	L maximum	max. lateral offset	DN mm	angular rotation
130mm	+5-0mm	120mm	135mm	100mm	160mm	±30mm	25-50	±30°
150mm	+5-0mm	140mm	155mm	115mm	180mm	±30mm	65-80	±25°
160mm	+5-0mm	145mm	170mm	125mm	195mm	±35mm	100-150	±20°
175mm	+5-0mm	160mm	185mm	135mm	210mm	±35mm	200-300	±10°
200mm	+5-0mm	180mm	210mm	160mm	235mm	±35mm	350-600	±8°
250mm	±6mm	230mm	260mm	210mm	285mm	±35mm	700-800	±6°
300mm	±10mm	280mm	310mm	260mm	340mm	±40mm	900-1000	±5°

Approvals available on request



Bellow Stamping

TYPE ERV . DN 80 PN 16.3in.

R 10 ³ - 10 ⁶ Ohm Electric conductivity tested	BF 05 TÜS - 12 Type approved
---	---------------------------------

ERV-G with space saving special flanges

With 2-hole oval flanges DIN 5435 of carbon steel, zinc plated

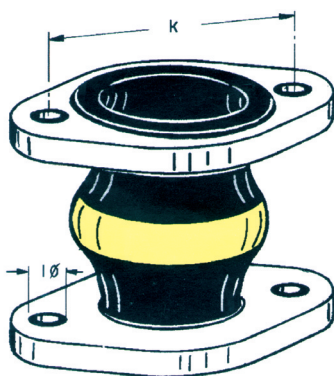

BL = 130mm

DN mm	k mm	l ø mm
32	78	11
40	82	11
50	100	11

PN 2.5

With 3-hole triangular flanges of carbon steel, zinc plated

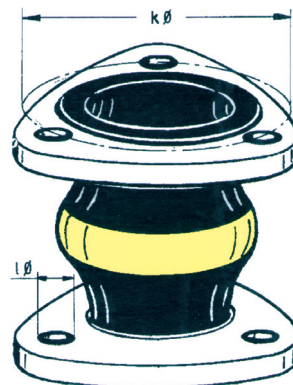

BL = 130mm

DN mm	k mm	l ø mm
32	78	11
40	82	11
50	100	11

PN 2.5

With 4-hole quadratic flanges of carbon steel, zinc plated

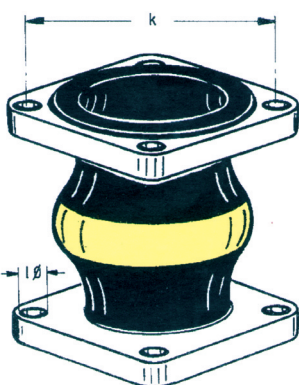

BL = 130mm

DN mm	k mm	l ø mm
32	76	11
40	84	11
50	96	11
65	116	11
80	126	11

PN 6

With 8-hole "TW" flanges DIN 28 461 of carbon steel, zinc plated

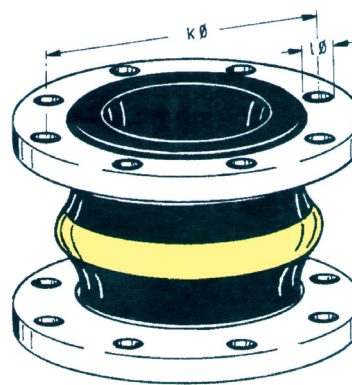

BL = 130mm

DN mm	k mm	l ø mm
50	130	11.5
65	130	11.5
80	130	11.5
100	150	14

PN 10

Expansion Joints with Steel Flanges



Weight App	Effect Area	Bellow Size DN		Press Nom.	Flange (1) Measurements mm			Length BL	Part Number
		kg	Q:cm ²		in.	mm	D		
1.6	15	1"	25	Refer to text	115	85	4x14	130	ERV-OR 25.25
3.0	15	1 1/4"	32		140	100	4x18	130	ERV-OR 32.25
3.3	20	1 1/2"	40		150	110	4x18	130	ERV-OR 40.25
4.8	30	2"	50		165	125	4x18	130	ERV-OR 50.25
5.7	50	2 1/2"	65		185	145	8x18	130	ERV-OR 65.25
7.5	85	3"	80		200	160	8x18	130	ERV-OR 80.25
10.4	125	4"	100		235	190	8x22	130	ERV-OR 100.25
1.5	15	1"	25		16	115	85	4x14	130
2.5	15	1 1/4"	32	16	140	100	4x18	130	ERV-GR 32.16
3.0	20	1 1/2"	40	16	150	110	4x18	130	ERV-GR 40.16
4.0	30	2"	50	16	165	125	4x18	130	ERV-GR 50.16
4.5	50	2 1/2"	65	16	185	145	4x18	130	ERV-GR 65.16
5.5	85	3"	80	16	200	160	8x18	130	ERV-GR 80.16
7.0	125	4"	100	16	220	180	8x18	130	ERV-GR 100.16
8.5	185	5"	125	16	250	210	8x18	130	ERV-GR 125.16
11.0	250	6"	150	10	285	240	8x22	130	ERV-GR 150.16
17.0	400	8"	200	10	340	295	8x22	130	ERV-GR 200.10
23.5	600	10"	250	10	395	350	12x22	130	ERV-GR 250.10
27.0	800	12"	300	10	445	400	12x22	130	ERV-GR 300.10
39.5	1000	14"	350	10	505	460	16x22	200	ERV-GR 350.10
42.0	1375	16"	400	10	565	515	16x26	200	ERV-GR 400.10
59.5	2185	20"	500	10	670	620	20x26	200	ERV-GR 500.10
70.0	3080	24"	600	10	780	725	20x30	200	ERV-GR 600.10
1.5	15	1"	25	16	115	85	4x14	130	ERV-W 25.16
2.5	15	1 1/4"	32	16	140	100	4x18	130	ERV-W 32.16
3.0	20	1 1/2"	40	16	150	110	4x18	130	ERV-W 40.16
4.0	30	2"	50	16	165	125	4x18	130	ERV-W 50.16
4.5	50	2 1/2"	65	16	185	145	4x18	130	ERV-W 65.16
5.5	85	3"	80	16	200	160	8x18	130	ERV-W 80.16
7.0	125	4"	100	16	220	180	8x18	130	ERV-W 100.16
8.5	185	5"	125	16	250	210	8x18	130	ERV-W 125.16
11.0	250	6"	150	10	285	240	8x22	130	ERV-W 150.16
17.0	400	8"	200	10	340	295	8x22	130	ERV-W 200.10
23.5	600	10"	250	10	395	350	12x22	130	ERV-W 250.10
27.0	800	12"	300	10	445	400	12x22	130	ERV-W 300.10
39.5	1000	14"	350	10	505	460	16x22	200	ERV-W 350.10
42.0	1375	16"	400	10	565	515	16x26	200	ERV-W 400.10
59.5	2185	20"	500	10	670	620	20x26	200	ERV-W 500.10
70.0	3080	24"	600	10	780	725	20x30	200	ERV-W 600.10

Type ERV - Orange Band

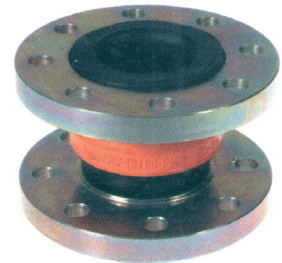

ORANGE BAND expansion joints for Liquid Petroleum gas (LPG). For tank trucks and refueling stations. Working temperature -30° C up to +70° C. Working pressure max. 20 bar. Burst pressure > 100 bar.

Liner: NBR (nitrile), seamless, electrically conductive

Reinforcement: Nylon® textile cord, warmth stabilized, NBR rubberized

Cover: Chloroprene (CR), pricked, electrically conductive

Flanges: swiveling, DIN 2635/PN 40 carbon steel C 22.8, zinc pl. + yellow chr.*)

Type ERV - Green Band

GREEN BAND

expansion joints for Acids, alkalis, chemicals and aggressive chemical waste water up to +80° C. For oil-contaminated compressed air up to +90° C. For particularly aggressive acids the admissible working temperature is reduced.

Liner: Hypalon (CSM)

Reinforcement: Nylon® textile cord

Cover: Hypalon (CSM)

Flanges: swiveling, PN 10/16, carbon steel, zinc plated + yellow chromated*)

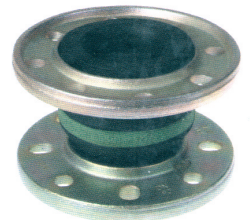

Type ERV - White Band

WHITE BAND

expansion joints for EDIBLE Liquids, vegetable oils and other foodstuffs requiring sanitary rubber compound, Temperature up to +80° C. 100° C is allowable for a brief cleaning. Not approved for drinking water.

Liner: Nitrile white (NBR)

Reinforcement: Nylon® textile cord

Cover: Chloroprene (CR)

Flanges: swiveling, PN 10/16, carbon steel, zinc plated + yellow chromated*)

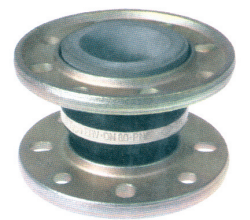

Technical Data

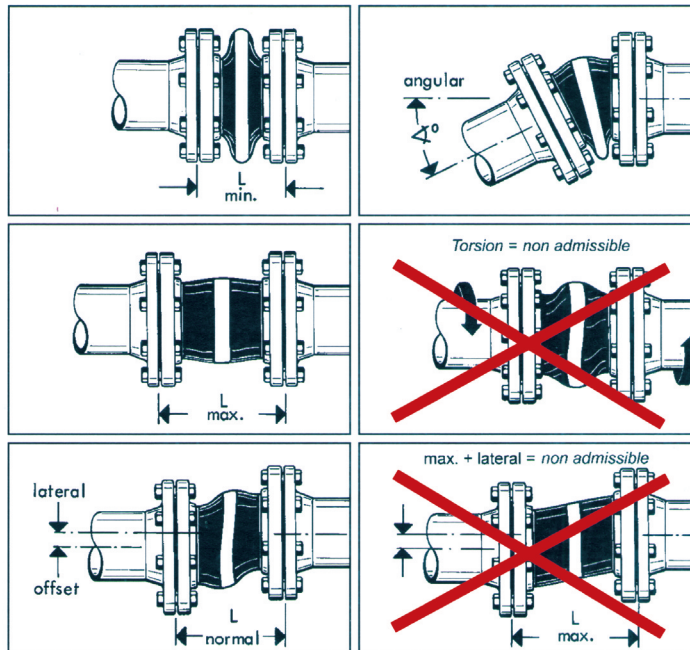
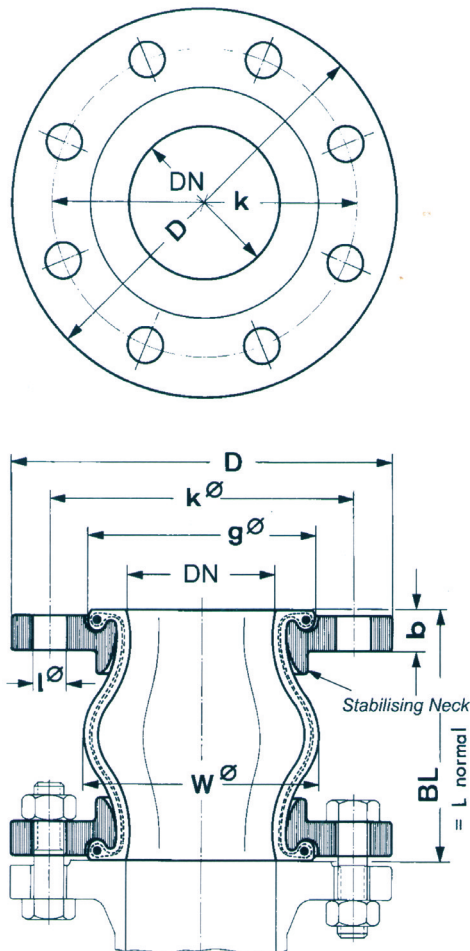

Allowable strain at simultaneous elongation and lateral movement

Length	L	mm	130	140	150	160
Lateral offset	max. ±	mm	30	20	10	0

For working pressure, max. Vacuum and range of movement

Up to 50°C – utilization ~ 100%
Up to 70°C – utilization ~ 175%
Up to 90°C – utilization ~ 60%

Type CR only to be used up to 70°C

ERV DIMENSIONS									ALLOWABLE SERVICE CONDITIONS FOR TYPES YELLOW, RED, GREEN, WHITE + CR*)										
SIZE		NOM PRESS	FLANGE CONNECTIONS ACC. TO DIN 2501						Working Pressure	Test Pressure VSD	MAX. VACUUM AT L = NORMAL			RANGE OF MOVEMENTS					
DN mm	in.	D PN	kø mm	gø mm	lø mm	b mm	wø mm	mm			bar	bar	mWs	mWs	mm	L min.	L max.	L offset	L rotation
25**	1"	10/16	115	80	66	4x14	18	81	16	25	7	-	-	130	100	160	30	30°	
32	1 1/4"	10/16	140	100	66	4x14	18	81	16	25	7	-	-	130	100	160	30	30°	
40	1 1/2"	10/16	150	110	70	4x18	19	86	16	25	7	-	-	130	100	160	30	30°	
50	2"	10/16	165	125	84	4x18	19	96	16	25	5	10	-	130	100	160	30	30°	
65	2 1/2"	10/16	185	145	105	4x18	19	111	16	25	5	10	-	130	100	160	30	25°	
80	3"	10/16	200	160	116	8x18	21	122	16	25	5	10	-	130	100	160	30	25°	
100	4"	10/16	220	180	138	8x18	21	142	16	25	3	10	-	130	100	160	30	20°	
125	5"	10/16	250	210	165	8x18	21	168	16	25	3	8	10	130	100	160	30	20°	
150	6"	10/16	285	240	190	8x22	21	192	16	25	-	7	10	130	100	160	30	20°	
200	8"	10	340	295	250	8x22	26	252	16*	25**)	-	7	10	130	100	160	30	10°	
250	10"	10	395	350	300	12x22	26	302	16*	25***)	-	6	10	130	100	160	30	10°	
300	12"	10	445	400	350	12x22	26	354	16*	25***)	-	6	10	130	100	160	30	10°	
350	14"	10	505	460	420	16x22	26	430	16*	25***)	-	-	10	200	160	235	35	8°	
400	16"	10	565	515	455	16x26	26	480	10	16	-	-	10	200	160	235	35	8°	
500	20"	10	670	620	555	20x26	28	580	10	16	-	-	7	200	160	235	35	8°	
600	24"	10	780	725	670	20x30	30	680	10	16	-	-	7	200	160	235	35	8°	
700	28"	10	895	840	780	24x30	30	820	10	16	-	-	-	275	235	310	35	6°	
800	32"	10	1015	950	885	24x33	32	890	10	16	-	-	-	250	210	285	35	6°	
900	36"	10	1115	1050	980	28x33	34	1020	10	16	-	-	-	300	260	340	40	5°	
1000	40"	10	1230	1160	1085	28x36	34	1120	10	16	-	-	-	300	260	340	40	5°	

*) The allowable service conditions are valid when flanges with stabilising neck are used.

**) For Teddington Expansion Joints bellows DN 32 are used.

***) The stated pressure rates are allowed when using appropriate flanges.

Yellow Steel Expansion Joints with Steel Flanges

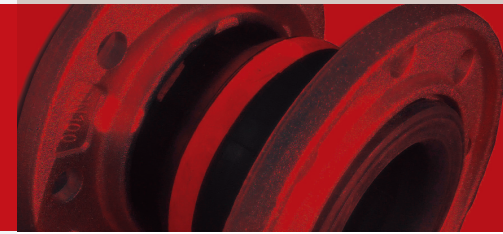

Weight App kg	Effect Area Q:cm ²	Bellow Size DN		Press Nom. bar	Flange (1) Measurements mm			Length BL mm	Part Number Type
		in.	mm		D	kø	I x ø		
1.5	10	1"	25	16	115	85	4x14	130	ERV-GS 25.16 ²⁾
2.5	15	1 1/4"	32	16	140	100	4x18	130	ERV-GS 32.16
3.0	20	1 1/2"	40	16	150	110	4x18	130	ERV-GS 40.16
4.0	30	2"	50	16	165	125	4x18	130	ERV-GS 50.16
4.5	50	2 1/2"	65	16	185	145	4x18	130	ERV-GS 65.16
5.5	85	3"	80	16	200	160	8x18	130	ERV-GS 80.16
5.6	85	3"	80	16	200	160	8x18	150	ERV-GS 80.150.16
7.0	125	4"	100	16	220	180	8x18	130	ERV-GS 100.16
7.1	125	4"	100	16	220	180	8x18	150	ERV-GS 100x150.16
8.5	185	5"	125	16	250	210	8x18	130	ERV-GS 125.16
8.6	185	5"	125	16	250	210	8x18	150	ERV-GS 125x150.16
11.0	250	6"	150	16	285	240	8x22	130	ERV-GS 150.16
11.1	250	6"	150	16	285	240	8x22	150	ERV-GS 150x150.16
17.0	400	8"	200	10	340	295	8x22	130	ERV-GS 200.10
17.3	400	8"	200	10	340	295	8x22	175	ERV-GS 200x175.10
23.5	600	10"	250	10	395	350	12x22	130	ERV-GS 250.10
23.8	600	10"	250	10	395	350	12x22	175	ERV-GS 250x175.10
27.0	800	12"	300	10	445	400	12x22	130	ERV-GS 300.10
27.5	800	12"	300	10	445	400	12x22	200	ERV-GS 300x200.10
39.5	1000	14"	350	10	505	460	16x22	200	ERV-GS 350.10
42.0	1375	16"	400	10	565	515	16x26	200	ERV-GS 400.10

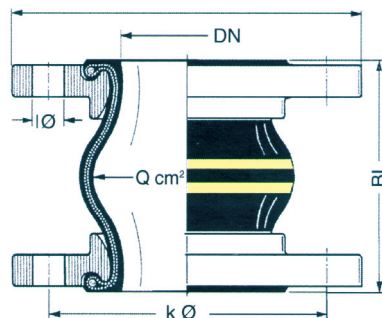

For the use in ship's engine rooms the required flame resistance is achieved with YELLOW STEEL expansion joints without an additional flame protection cover. Type approvals are available from classification companies shown below.



Type ERV - Yellow Steel

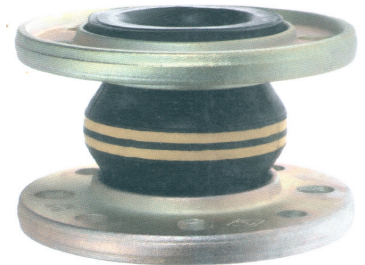

YELLOW STEEL expansion joints with steel swivel flanges and smooth holes for bolts, for permanent high temperature. Up to 60° C max. 16 bar, up to 100° C max. 10 bar. Suitable for: cooling water with oily anticorrosion additives, lubrication oil, seawater, diesel.

Liner: NBR (nitrile), seamless, electrically conductive

Reinforcement: steel wire cord, CR rubberised

Cover: Chloroprene CR (neoprene)

Marking: 2 yellow bands, ERV size - DN...PN 16, production date

Flanges: Swivelling, carbon steel, zinc plated and yellow chromated

Usage: Cooling water and lubrication oil pipe lines on ships' and stationary diesel engines, for example in sludge draining plants, waste water processing and treatments plants, block heating power stations, heat recovery plants, seawater desalination plants, emergency power units

Application: Vibration absorption, Noise reduction, Thermal expansion absorption

1) Other flange standards and materials available on request, for example DIN PN 6, PN 25/40, ANSI B 16.5 (ASA 150 lbs.), BS10 table E,F, H Flanges of stainless steel 1.4571, brass or hot galvanised steel.

2) For Teddington Expansion joints ERV-GS 25. 16 Bellows DN 32 are used.

CR Expansion Joints with Steel Flanges

Type ERV - Black Band



BLACK BAND Expansion Joints for cold and warm water, swimming pool water, washing water, sea water, but not for drinking water (dechlorination - smell - taste).

For waste water, for weak sour or alkaline water - also oil containing, but not for acids, alkalis and chemicals.

For cooling water - also sea water with protective oils against corrosion.

For lubricating oil and grease, but not for heating oil, diesel, gasoline and jet fuel, petroleum, solvents and other hydrocarbons.

For air, compressed air, but not for hot compressed air and not for LPG.

Temperature range: -20° C up to +70° C, briefly up to +90° C.

Tube: Chloroprene CR, black, not electrically conductive

Reinforcement: Nylon textile cord

Cover: Chloroprene CR, black, not electrically conductive

Marking: dimension, PN 16, production date, with imprint "CR"

Flanges: swiveling, carbon steel, zinc plated and yellow chromated

1) Other flange standards and materials available on request, for example DIN PN 6, PN 25/40, ANSI B 16.5 (ASA 150 lbs.), BS 10 table E, F, H. Flanges of stainless steel 1.4571, brass or hot galvanized steel.

2) For ELAFLEX Expansion Joints ERV-CR 25.16 bellows DN 32 are used.

Weight App	Effect Area	Bellow Size DN		Press Nom.	Flange (1) Measurements mm			Length BL	Part Number
		in.	mm		D	kø	l x ø		
1,5	15	1"	25	16	115	85	4 x 14	130	ERV-CR 25.16 2
2,5	15	1 1/4"	32	16	140	100	4 x 18	130	ERV-CR 32.16
3,0	20	1 1/2"	40	16	150	110	4 x 18	130	ERV-CR 40.16
4,0	30	2"	50	16	165	125	4 x 18	130	ERV-CR 50.16
4,5	50	2"	65	16	185	145	4 x 18	130	ERV-CR 65.16
5,5	85	3"	80	16	200	160	8 x 18	130	ERV-CR 80.16
7,0	125	4"	100	16	220	180	8 x 18	130	ERV-CR 100.16
8,5	185	5"	125	16	250	210	8 x 18	130	ERV-CR 125.16
11,0	250	6"	150	16	285	240	8 x 22	130	ERV-CR 150.16
17,0	400	8"	200	10	340	295	8 x 22	130	ERV-CR 200.16
23,5	600	10"	250	10	395	350	12 x 22	130	ERV-CR 250.16
27,0	800	12"	300	10	445	400	12 x 22	130	ERV-CR 300.16
39,5	1000	14"	350	10	505	460	16 x 22	200	ERV-CR 350.16
42,0	1375	16"	400	10	565	515	16 x 26	200	ERV-CR 400.16
59,5	2185	20"	500	10	670	620	20 x 26	200	ERV-CR 500.16
70,0	3080	24"	600	10	780	725	20 x 30	200	ERV-CR 600.16
135,0	4800	28"	700	10	895	840	24 x 30	275	ERV-CR 700.16
125,0	5440	32"	800	10	1015	950	24 x 33	250	ERV-CR 800.16
205,0	7100	36"	900	10	1115	1050	28 x 33	300	ERV-CR 900.16
245,0	8700	40"	1000	10	1230	1160	28 x 36	300	ERV-CR 1000.16

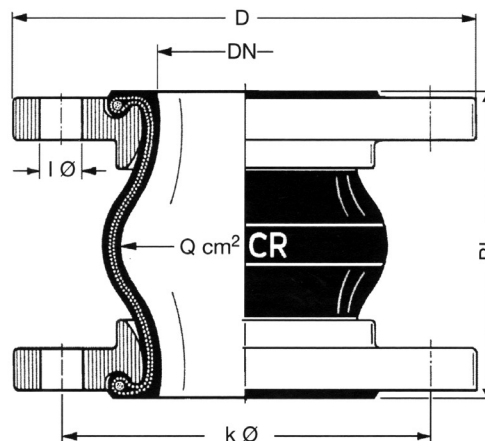

Technical Data for Type ERV - Black Band



WORKING PRESSURE	at room temperature	16 bar
	with 70° C water	10 bar
TEST PRESSURE	at normal cold water	25 bar
BURST PRESSURE	at normal cold water	>50 bar
VACUUM	for the allowable vacuum with and without support ring see page 1-6	
PRESSURE DROP ANCHOR POINTS TIE BARS NOISE ABSORPTION	Notice the hints for the special types ERV - Yellow Band - Red Band - Green Band on which are valid also for ERV-CR.	
CORRECT MATING FLANGE	To achieve a long service life without disturbance the mating flange must meet the requirements described on catalogue page xx	
APPROVALS	Official approvals for type CR regarding the installations in tank trucks and heating plants will not be applied.	

Allowable Range of Movement for Type ERV - Black Band

Length		Recommended Installation Lgth		Allowable Range of Movement in Service*				
130mm	+5-0mm	120mm	135mm	100mm	160mm	±30mm	25-30	±30°
150mm	+5-0mm	140mm	155mm	115mm	180mm	±30mm	65-80	±25°
160mm	+5-0mm	145mm	170mm	125mm	195mm	±35mm	100-150	±20°
175mm	+5-0mm	160mm	185mm	135mm	210mm	±35mm	200-300	±10°
200mm	+5-0mm	180mm	210mm	160mm	235mm	±35mm	350-600	±8°
250mm	±6mm	230mm	260mm	210mm	285mm	±35mm	700-800	±6°
300mm	±10mm	280mm	310mm	260mm	340mm	±40mm	900-1000	±5°

*Temperature Dependency on Movement Compensation:

The data is valid for temperatures up to 60° Celsius. At operating temperatures of 70°C the allowable utilization factor is approx. 80 %. At operating temperatures 90°C it is approx. 70%.

ERV Black Band Notes:

The black "CR" expansion joints are made in the same moulds with the same nylon-cord reinforcement as the special types of ERV bellows that are identified with coloured bands. They are also supplied with the same high quality, forged steel, zinc plated flanges.

The CR is intended for less arduous applications than the other ERV bellows types and employs chloroprene for both liner and cover. The resistance of the ERV-CR to water, wear, tear and ageing is excellent in simpler applications and comparable to the ERV special types.

Red Band Expansion Joints with Steel Flanges

Type ERV - Red Band

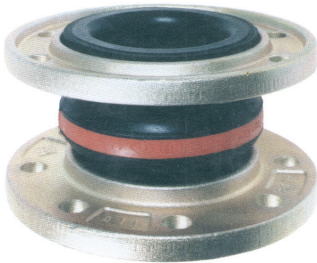

RED BAND expansion joints in High-Tech design for water, drinking water, cold and warm waste water, seawater, cooling water, also with chemical additives for water treatment up to 90° Celsius. Working pressure as per chart up to 16 bar. Allowable vacuum see overleaf. Also very suitable for chemical waste water (without oil containing additives), chemicals, acids and alkalis, salt solutions, technical alcohols, esters and ketones.

Not suitable for all kinds of mineral oil products, cooling water with added oil containing corrosion preventatives, oily compressor air.

Tube: Butyl/EPDM compound, non-permeable, elec. conductive

Reinforcement: Nylon textile cord, Butyl rubberized, non-hardening

Cover: EPDM, ozone proof, warmth resistant, elec. conductive

Stamping: Red band, ERV size - DN ... PN16, production date

Flanges: swiveling, carbon steel, zinc plated and yellow chromated



Approved for drinking water

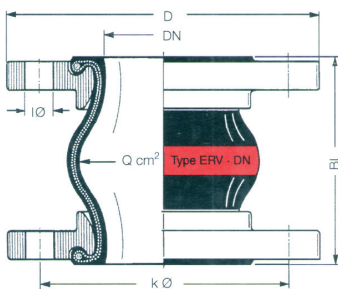

1) Other flange standards and materials available on request, for example DIN PN 6, PN 25/40, ANSI B 16.5 (ASA 150 lbs.) BS 10 table E, F, H. Flanges of stainless steel 1.4571, brass or hot galvanized steel.

2) For Expansion Joints ERV-R 25.16 bellows DN 32 are used.

Weight App	Effect Area	Bellows Size DN		Press Nom.	Flange (1) Measurements mm			Length BL	Part Number
		in.	mm		D	kØ	l x ø		
1,5	15	1"	25	16	115	85	4 x 14	130	ERV-R 25. 16 2)
2,5	15	1 1/4"	32	16	140	100	4 x 18	130	ERV-R 32. 16
2,7	15	1 1/4"	32	16	140	100	4 x 18	160	ERV-R 32x160. 16
3,0	20	1 1/2"	40	16	150	110	4 x 18	130	ERV-R 40. 16
3,2	20	1 1/2"	40	16	150	110	4 x 18	160	ERV-R 40x160. 16
4,0	30	2"	50	16	165	125	4 x 18	130	ERV-R 50. 16
4,1	30	2"	50	16	165	125	4 x 18	150	ERV-R 50x150. 16
4,2	30	2"	50	16	165	125	4 x 18	160	ERV-R 50x160. 16
4,5	50	2 1/2"	65	16	185	145	4 x 18	130	ERV-R 65. 16
4,6	50	2 1/2"	65	16	185	145	4 x 18	150	ERV-R 65x150. 16
4,7	50	2 1/2"	65	16	185	145	4 x 18	160	ERV-R 65x160. 16
5,5	85	3"	80	16	200	160	8 x 18	130	ERV-R 80.16
5,6	85	3"	80	16	200	160	8 x 18	150	ERV-R 80x150. 16
5,7	85	3"	80	16	200	160	8 x 18	160	ERV-R 80x160. 16
7,0	125	4"	100	16	220	180	8 x 18	130	ERV-R 100. 16
7,1	125	4"	100	16	220	180	8 x 18	150	ERV-R 100x150. 16
7,2	125	4"	100	16	220	180	8 x 18	160	ERV-R 100x160. 16
8,5	185	5"	125	16	250	210	8 x 18	130	ERV-R 125. 16
8,6	185	5"	125	16	250	210	8 x 18	150	ERV-R 125x150. 16
8,7	185	5"	125	16	250	210	8 x 18	160	ERV-R 125x160. 16
11,0	250	6"	150	16	285	240	8 x 22	130	ERV-R 150.16
11,1	250	6"	150	16	285	240	8 x 22	150	ERV-R 150x150. 16
11,2	250	6"	150	16	285	240	8 x 22	160	ERV-R 150x160. 16
17,0	400	8"	200	10	340	295	8 x 22	130	ERV-R 200. 10
17,1	400	8"	200	10	340	295	8 x 22	150	ERV-R 200x150. 10
17,2	400	8"	200	10	340	295	8 x 22	160	ERV-R 200x160. 10
17,3	400	8"	200	10	340	295	8 x 22	175	ERV-R 200x175. 10
23,5	600	10"	250	10	395	350	12 x 22	130	ERV-R 250. 10
23,8	600	10"	250	10	395	350	12 x 22	175	ERV-R 250x175. 10
24,0	600	10"	250	10	395	350	12 x 22	200	ERV-R 250x200. 10
27,0	800	12"	300	10	445	400	12 x 22	130	ERV-R 300. 10
27,5	800	12"	300	10	445	400	12 x 22	200	ERV-R 300x200. 10
39,5	1000	14"	350	10	505	460	16 x 22	200	ERV-R 350. 10
42,0	1375	16"	400	10	565	515	16 x 26	200	ERV-R 400. 10
59,5	2185	20"	500	10	670	620	20 x 26	200	ERV-R 500. 10
70,0	3080	24"	600	10	780	727	20 x 30	200	ERV-R 600. 10
135,0	4800	28"	700	10	895	840	24 x 30	275	ERV-R 700. 10
125,0	5440	32"	800	10	1015	950	24 x 33	250	ERV-R 800. 10
205,0	7100	36"	900	10	1115	1050	28 x 33	300	ERV-R 900. 10
245,0	8700	40"	1000	10	1230	1160	28 x 36	300	ERV-R 1000. 10

Estimated Service Life at Warm Water Operation



The chart shows the result of the High-Tech type "ERV-R" DN 80 with warmth stabilized reinforcements of Nyloncord in comparison to the types ERP and CR. The values are extrapolated according to practical gained experiences and test results. The other sizes are of the same construction and have the same ageing properties caused through warmth while they are in service permanently with hot water.

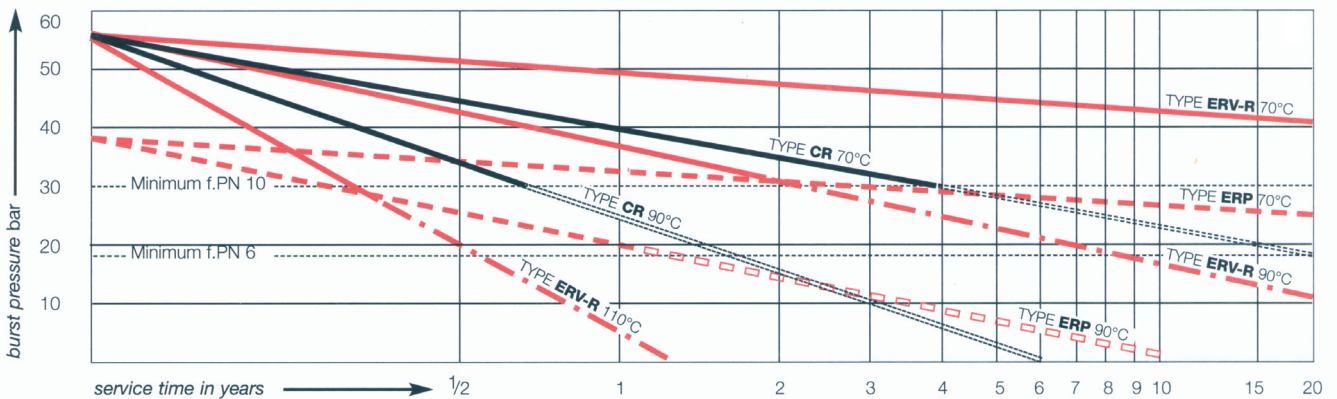

Allowable Range of Movement for Type ERV - Red Band

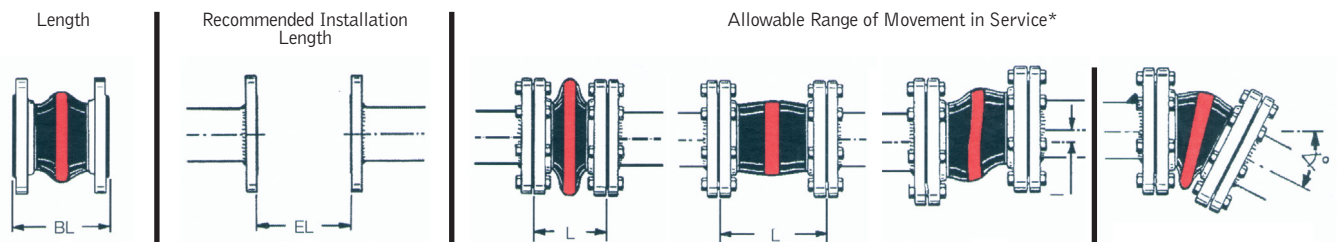

BL	Tolerance	EL Minimal	EL Maximum	L Minimal	L Maximum	Max Lateral Offset	DN mm	Rotation
130mm	+5-0mm	120mm	135mm	100mm	160mm	±30mm	25-30	±30°
150mm	+5-0mm	140mm	155mm	115mm	180mm	±30mm	65-80	±25°
160mm	+5-0mm	145mm	170mm	125mm	195mm	±35mm	100-150	±20°
175mm	+5-0mm	160mm	185mm	135mm	210mm	±35mm	200-300	±10°
200mm	+5-0mm	180mm	210mm	160mm	235mm	±35mm	350-600	±8°
250mm	±6mm	230mm	260mm	210mm	285mm	±35mm	700-800	±6°
300mm	±10mm	280mm	310mm	260mm	340mm	±40mm	900-1000	±5°

*Temperature Dependency on Movement Compensation:

The data is valid for temperatures up to 60° Celsius. At operating temperatures of 70°C the allowable utilization factor is approx. 80%. At operating temperatures 90°C it is approx. 70%.

Allowable Range of Pressure for Type ERV - Red Band

Size	Pressure Nom.	Test Pressure	Maximum Allowable Service - Pressure Warm Water			Maximum Allowable Vacuum at Length BL		
			70°C	80°C	90°C	Without support ring	With support ring VSD	With support ring VSR
DN 25 - 40	16 bar	25 bar	14 bar	12 bar	10 bar	7 mWS	-	-
DN 50 - 80	16 bar	25 bar	14 bar	12 bar	10 bar	5 mWS	10 mWS	-
DN 100	16 bar	25 bar	14 bar	12 bar	10 bar	3 mWS	10 mWS	-
DN 125	16 bar	25 bar	14 bar	12 bar	10 bar	3 mWS	8 mWS	10 mWS
DN 150 - 200	16 bar	25 bar	14 bar	12 bar	10 bar	-	7 mWS	10 mWS
DN 250 - 300	10 bar	16 bar	8 bar	7 bar	6 bar	-	6 mWS	10 mWS
DN 350 - 400	10 bar	16 bar	8 bar	7 bar	6 bar	-	-	10 mWS
DN 500 - 600	10 bar	16 bar	8 bar	7 bar	6 bar	-	-	7 mWS

ROTEX Expansion Joints with Steel Flanges

Type ERV - ROTEX

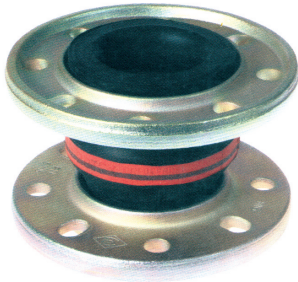

ROTEX expansion joints for permanent stress through hot heating water, cooling water and hot air. Approved according to DIN. Working pressure 10 bar up to 100° Celsius, 6 bar up to 110° Celsius, temporarily up to 130° Celsius. Further technical data and description see information 2.91.

Not suitable for drinking water, cooling water with oil containing additives, oily compressor air, permanent effect of steam, corrosion preventative. Resistance against water additives please see our information 10.79.

Tube: EPDM, hot water resistant, non-permeable, conductive Reinforcement: Polymer textile cord, hot water and hydrolysis proof

Cover: EPDM, ozone proof, warmth resistant, elec. conductive

Flanges: swiveling, carbon steel, zinc plated and yellow chromated

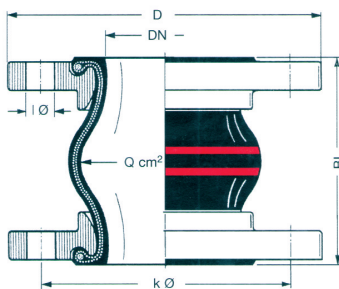

1) Other flange standards and materials available on request, for example DIN PN 6, PN 25/40, ANSI B 16.5 (ASA 150 lbs.), BS 10 table E, F, H. Flanges of stainless steel 1.4571, brass or hot galvanized steel.

21 For Teddington Expansion Joints ROTEX 25.16 bellows DN 32 are used.

Weight App	Effect Area	Bellows Size DN		Press Nom.	Flange (1) Measurements mm			Length BL	Part Number
		in.	mm		D	kø	l x ø		
1,5	15	1"	25	16	115	85	4 x 14	130	ROTEX 25.16 2
2,5	15	1 1/4"	32	16	140	100	4 x 18	130	ROTEX 32.16
3,0	20	1 1/2"	40	16	150	110	4 x 18	130	ROTEX 40.16
4,0	30	2"	50	16	165	125	4 x 18	130	ROTEX 50.16
4,2	30	2"	50	16	165	125	4 x 18	160	ROTEX 50x160.16
4,5	50	2 1/2"	65	16	185	145	4 x 18	130	ROTEX 65.16
4,7	50	2 1/2"	65	16	185	145	4 x 18	160	ROTEX 65x160.16
5,5	85	3"	80	16	200	160	8 x 18	130	ROTEX 80.16
5,6	85	3"	80	16	200	160	8 x 18	150	ROTEX 80x150.16
5,7	85	3"	80	16	200	160	8 x 18	160	ROTEX 80x160.16
7,0	125	4"	100	16	220	180	8 x 18	130	ROTEX 100.16
7,1	125	4"	100	16	220	180	8 x 18	150	ROTEX 100x150.16
7,2	125	4"	100	16	220	180	8 x 18	160	ROTEX 100x160.16
8,5	185	5"	125	16	250	210	8 x 18	130	ROTEX 125.16
8,6	185	5"	125	16	250	210	8 x 18	150	ROTEX 125x150.16
8,7	185	5"	125	16	250	210	8 x 18	160	ROTEX 125x160.16
11,0	250	6"	150	16	285	240	8 x 22	130	ROTEX 150.16
11,1	250	6"	150	16	285	240	8 x 22	150	ROTEX 150x150.16
11,2	250	6"	150	16	285	240	8 x 22	160	ROTEX 150x160.16
17,0	400	8"	200	10	340	295	8 x 22	130	ROTEX 200.10
17,1	400	8"	200	10	340	295	8 x 22	150	ROTEX 200x150.10
17,2	400	8"	200	10	340	295	8 x 22	160	ROTEX 200x160.10
17,3	400	8"	200	10	340	295	8 x 22	175	ROTEX 200x175.10
23,5	600	10"	250	10	395	350	12 x 22	130	ROTEX 250.10
23,8	600	10"	250	10	395	350	12 x 22	175	ROTEX 250x175.10
24,0	600	10"	250	10	395	350	12 x 22	200	ROTEX 250x200.10
27,0	800	12"	300	10	445	400	12 x 22	130	ROTEX 300.10
27,5	800	12"	300	10	445	400	12 x 22	200	ROTEX 300x200.10
39,5	1000	14"	350	10	505	460	16 x 22	200	ROTEX 350.10
42,0	1375	16"	400	10	565	515	16 x 26	200	ROTEX 400.10
59,5	2185	20"	500	10	670	620	20 x 26	200	ROTEX 500.10
70,0	3080	24"	600	10	780	725	20 x 30	200	ROTEX 600.10
135,0	4800	28"	700	10	895	840	24 x 30	275	ROTEX 700.10
125,0	5440	32"	800	10	1015	950	24 x 33	250	ROTEX 800.10
205,0	7100	36"	900	10	1115	1050	28 x 33	300	ROTEX 900.10
245,0	8700	40"	1000	10	1230	1160	28 x 36	300	ROTEX 1000.10

Application: Used as safety compensator in central heating installations according to standard DIN 4809 with design temperature up to 110° Celsius. For noise reduction, for compensation of axial, lateral and angular movements and vibrations. For allowable of movement and the estimated service life - see next page. This is ideal for high stress heating power stations.



Estimated Service Life at Hot Water Operation



The chart shows the curves for the type ERV-ROTEX DN 80 with polymer cord reinforcements that was tested for one year by the German licensing authorities with hot water at 130° Celsius. The values were extrapolated according to the test results and practical experience. The other sizes have the same ageing properties through warmth while being in service permanently with hot water. For comparison purposes the curves of the standard type ERV-ROT are also shown.

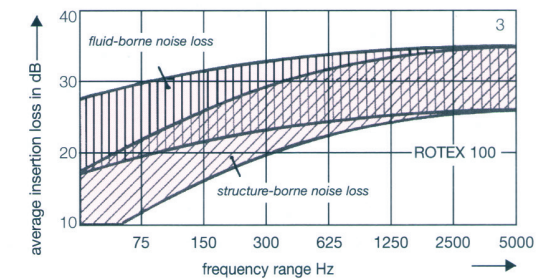
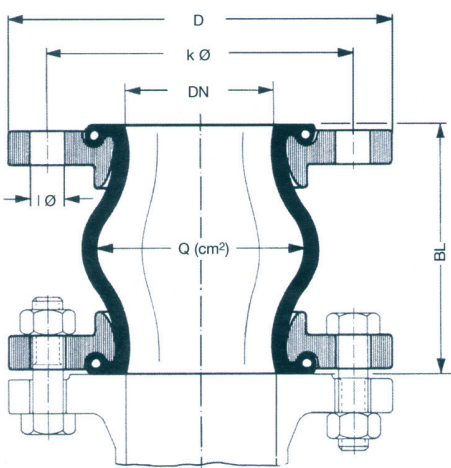
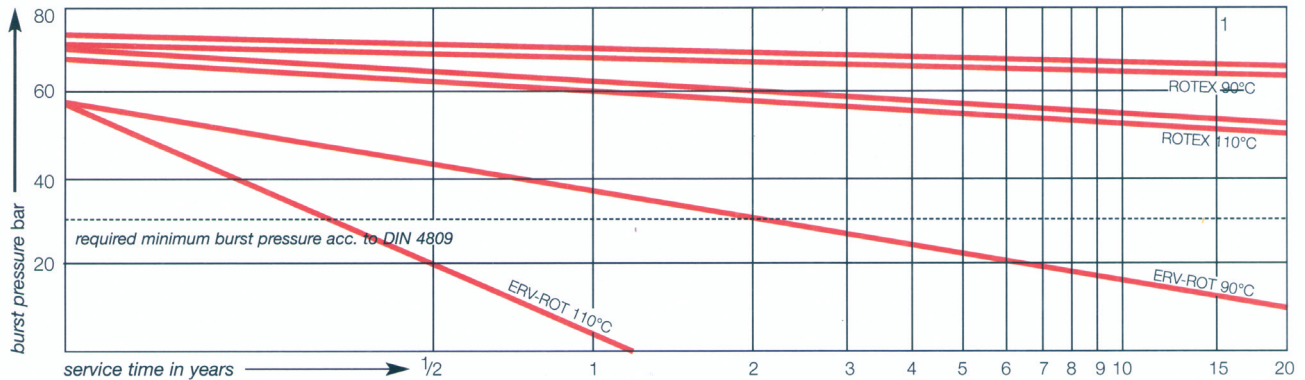

Noise level reduction through ROTEX

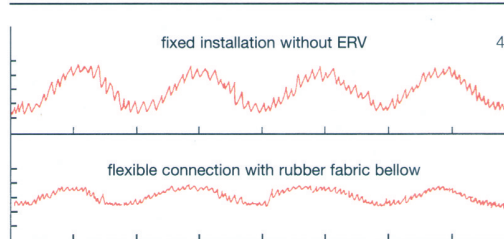

Allowable Range of Movement for Type ROTEX

Size	Recommended Installation Lgth		Allowable Range of Movement after Installation up to 70 °C*			
	Minimal	Maximum	Minimal	Maximum	Lateral Offset	Angular Rotation
ROTEX DN						
mm						
DN 25 – DN 80	BL -10 mm	BL +5 mm	BL minus 30 mm	BL plus 30 mm	± 20 mm	± 30°
DN 100 – DN 150	BL -10 mm	BL +5 mm	BL minus 30 mm	BL plus 30 mm	± 20 mm	± 20°
DN 200 – DN 300	BL -15 mm	BL +10 mm	BL minus 30 mm	BL plus 30 mm	± 20 mm	± 12°
DN 350 – DN 600	BL -20 mm	BL +10 mm	BL minus 40 mm	BL plus 35 mm	± 20 mm	± 8°
DN 700 – DN 1000	BL -20 mm	BL +15 mm	BL minus 40 mm	BL plus 35 mm	± 20 mm	± 5°

*Temperature Dependency on Movement Compensation:

The data is valid for temperatures up to 70° Celsius. At operating temperatures of 90°C the allowable utilization factor is equals 75%. At operating temperature 110°C equals 50%.

ERP Expansion Joints with Steel Flanges

Type ERP

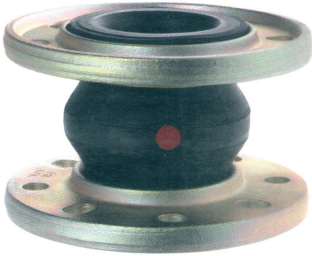

RED SPOT Expansion Joints Type ERP with swivelling steel flanges, for sanitary facilities, for cold and warm water, pool water, sea water, drinking water. Working pressure max. 10 bar up to 60°C; max. 6 bar up to 80°C.

Not suitable for heating systems with permanent temperatures of more than 80°C and for ozonized water.

Only two nyloncord reinforcements and therefore **highly flexible** and lower self resistance.

Tube: Butyl/EPDM compound, non-permeable, elec. conductive

Reinforcement: Nylon textile cord, butyl rubberized, non-hardening

Cover: EPDM, ozone proof, warmth resistant, elec. conductive

Stamping: red spot, DN PN 10, production date

Flanges: swivelling, carbon steel, zinc plated and yellow chromate

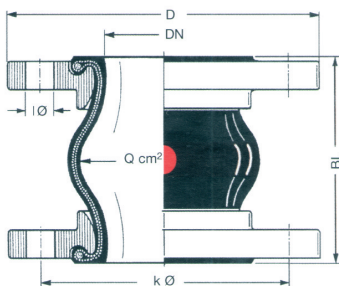

1) Other flange standards and materials available on request, for example DIN PN 6, PN 25/40, ANSI B 16.5 (ASA 150 lbs.), BS 10 table E, F H. Flanges of stainless steel 1.4571, brass or hot galvanized steel.

2) For Teddington Expansion Joints ERP 25.16 bellows DN 32 are used.

Weight App = kg	Effect Area Q: cm ²	Bellow Size DN		Press Nom. bar	Flange (1) Measurements mm			Length BL mm	Part Number Type
		in.	mm		D	kø	l x ø		
1,5	15	1"	25	10	115	85	4 x 14	130	ERP 25.102)
2,5	15	1 1/4"	32	10	140	100	4 x 18	130	ERP 32.10
3,0	20	1 1/2"	40	10	150	110	4 x 18	130	ERP 40.10
4,0	30	2"	50	10	165	125	4 x 18	130	ERP 50.10
4,5	50	2 1/2"	65	10	185	145	4 x 18	130	ERP 65.10
5,5	85	3"	80	10	200	160	8 x 18	130	ERP 80.10
7,0	125	4"	100	10	220	180	8 x 18	130	ERP 100.10
8,5	185	5"	125	10	250	210	8 x 18	130	ERP 125.10
11,0	250	6"	150	10	285	240	8 x 22	130	ERP 150.10

Test Pressure (room temp.): > 15 bar

Burst Pressure (room temp.): > 30 bar

Vacuum

"VSD"

Pressure Loss

Limiters

Counter Flanges

Not suitable for vacuum. Vacuum support spirals must not be used for type ERP.

Data of ERV Red Band are applicable

Type ERP: Allowable range of movement after installation up to 80°C

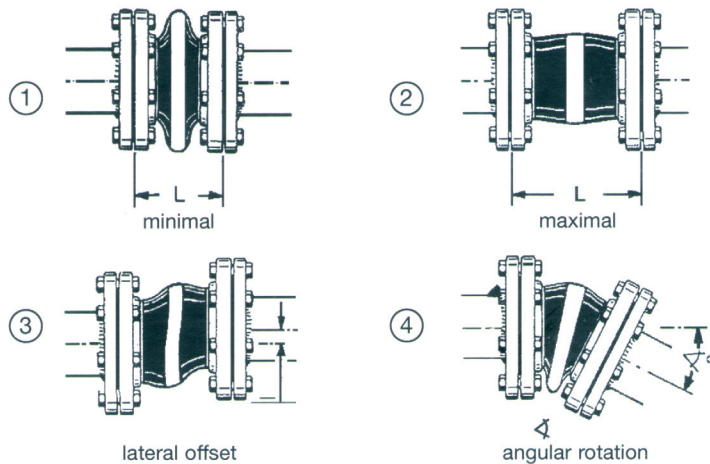

Size		STANDARD Inst Length		1	2	3l	4
mm	in.	min	max	L min	L max	lateral offset	angular rotation
25 ²	1"	25	135 mm	110 mm	150 mm	±15 mm	±30°
32	1 1/4"	25	135 mm	110 mm	150 mm	±15 mm	±30°
40	1 1/2"	25	135 mm	110 mm	150 mm	±15 mm	±30°
50	2"	25	135 mm	110 mm	150 mm	±15 mm	±30°
65	2 1/2"	25	135 mm	110 mm	150 mm	±15 mm	±25°
80	3"	25	135 mm	110 mm	150 mm	±15 mm	±25°
100	4"	25	135 mm	110 mm	150 mm	±15 mm	±20°
125	5"	25	135 mm	110 mm	150 mm	±15 mm	±20°
150	6"	25	135 mm	110 mm	150 mm	±15 mm	±15°

Accessories for Expansion Joints



	Diam Nom		Part Number
	*mm	mm	Type
Available for DN 25-300. Seamless lining with sealing surface, virgin PTFE, approx. 1 mm thickness. Delivered only as complete factory mounted unit with flanges. Unmounted lining not available. The allowable movement range of the ERV is restricted by approximately 50%.	25	26	ERV... 25... TA
	32	26	ERV... 32... TA
	40	34	ERV... 40... TA
	50	44	ERV... 50... TA
	65	59	ERV... 65... TA
	80	72	ERV... 80... TA
	100	92	ERV... 100... TA
	125	115	ERV... 125... TA
	150	138	ERV... 150... TA
	200	187	ERV... 200... TA
250	235	ERV... 250... TA	
300	285	ERV... 300... TA	
Available for DN 50-300. Seamless PTFE lining as "TA" but additionally with factory mounted support ring of solid RIFE. The allowable movement range is restricted by approximately 50%.	50	44	ERV... 50... TAS
	65	59	ERV... 65... TAS
	80	72	ERV... 80... TAS
	100	92	ERV... 100... TAS
	125	115	ERV... 125... TAS
	150	138	ERV... 150... TAS
	200	187	ERV... 200... TAS
	250	235	ERV... 250... TAS
	300	285	ERV... 300... TAS
Available for DN 50-300. Number of turns and material thickness vary with DN. The vacuum support spiral can be easily mounted subsequently. No 1 restriction of admissible pressure for ERV. Movement range restricted by approximately 50%.	50	85	ERV... 50... VSD
	65	110	ERV... 65... VSD
	80	130	ERV... 80... VSD
	100	180	ERV... 100... VSD
	125	230	ERV... 125... VSD
	150	270	ERV... 150... VSD
	200	320	ERV... 200... VSD
	250	420	ERV... 250... VSD
	300	500	ERV... 300... VSD
Available for DN 125-600. The vacuum support rings can be easily mounted subsequently. No restriction of admissible pressure for ERV. Movement range restricted by approximately 50%. Also available: Bolted support rings VSRV DN 500-100 for 1 bar vacuum.	125	175	ERV... 125... VSR
	150	190	ERV... 150... VSR
	200	260	ERV... 200... VSR
	250	300	ERV... 250... VSR
	300	350	ERV... 300... VSR
	350	430	ERV... 350... VSR
	400	480	ERV... 400... VSR
	500	580	ERV... 500... VSR
	600	680	ERV... 600... VSR

Type TA

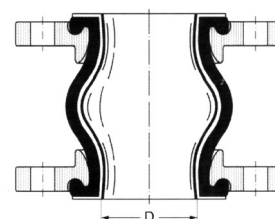

PTFE - LINING FOR ERV. Used when the chemical resistance of the chosen ERV type is not sufficient. Suitable for all kinds of liquids in use. Admissible working temperature of expansion joint has to be observed. For working pressure up to 6 bar - not suitable for vacuum.

Type TAS

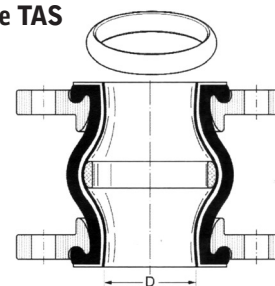

PTFE-LINING + VACUUM SUPPORT RING FOR ERV. Properties like type TA, but also suitable for vacuum service, up to 70°C.

Type VSD

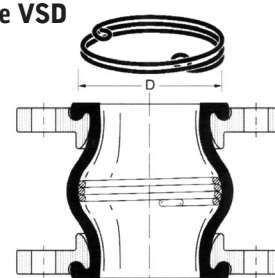

VACUUM SUPPORT SPIRAL FOR ERV. Spiral of AISI 316 Ti, used when the vacuum resistance of the chosen ERV is not sufficient.*)

Type VSR

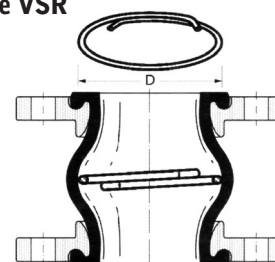

VACUUM SUPPORT RING FOR ERV. Ring of AISI 316 Ti, used when the vacuum resistance of the chosen ERV is not sufficient*)

* For type VSD & VSR: Admissible vacuum. See page 6

ERV with Tied Flanges - Type ZS

ERV with Tied Flanges - Type ZS

The table opposite shows that the pressure thrust forces in small ERV bellows up to DN 50 are low and that tie rods are not normally necessary. Tie rods are recommended when it is not possible to secure the pipe system with sufficient fixed points or when partial relief of the fixed points is desired.

The tie rods are designed to absorb the reaction forces resulting from the test pressure.

Below DN350 the tie rods are mounted in rubber bushes, for DN350 and above conical seats and spherical washers are supplied. The tie bars can be adjusted to suit the actual installation face-to-face distance.

DN	Number of Tie Rods*	Admissible Test Pressure**	Part Number
mm			Type
25	2	25	ERV 25 ... ZS
32	2	25	ERV 32 ... ZS
40	2	25	ERV 40 ... ZS
50	2	25	ERV 50 ... ZS
65	2	25	ERV 65 ... ZS
80	2	25	ERV 80 ... ZS
100	2	25	ERV 100 ... ZS
125	2	25	ERV 125 ... ZS
150	2	25	ERV 150 ... ZS
200	2	16	ERV 200 ... ZS
250	2	16	ERV 250 ... ZS
300	3	16	ERV 300 ... ZS
350	4	16	ERV 350 ... ZS
400	6	16	ERV 400 ... ZS
500	6	16	ERV 500 ... ZS
600	6	16	ERV 600 ... ZS

*) Number of tie rods subject to change

**) The compensator must not be lengthened or jolted at the pressure test.

Pressure thrust forces of ERV Expansion Joints
(installation length = 130 mm)

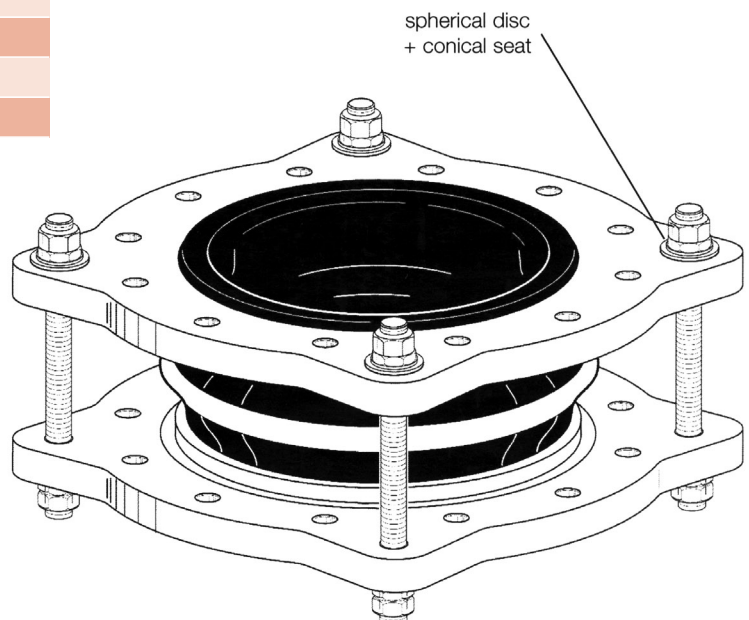
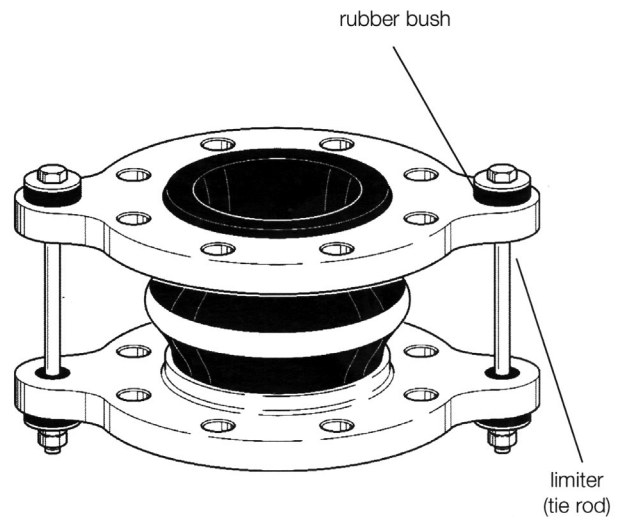
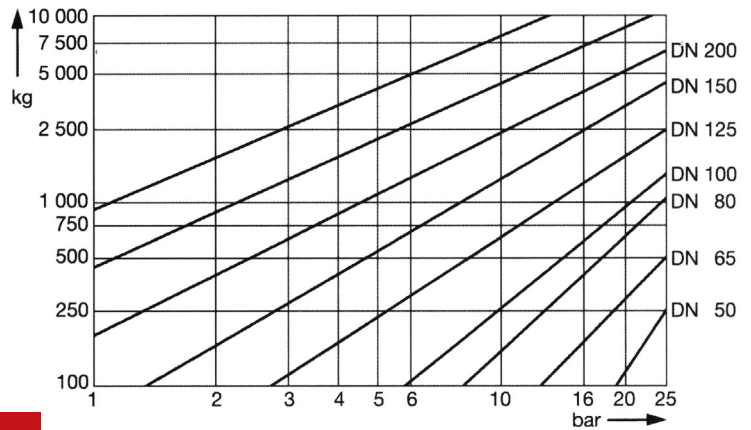

Hints for the Pipework Designer



Hints for the Pipework Designer

Rubber expansion joints, type ERV, are delivered ready for installation. The swivelling flanges can be fitted in any desired position. Standard flanges have stabilising rims which make assembly easier. Commercial quality screws can be fitted through the holes from both sides. The stabilising rim provides a way of ensuring a safety gap between the ends of the screws and the bellow throughout the whole range of movement and avoids injuries.

Correct counter flanges?

Washers/packers are not required if the sealing surface of the mating flanges on the pipework are of the same size. Otherwise packing washers (as shown in fig. 5) should be used in order to prevent damage on the rubber sealing surface due to the edges of the mating flanges having a too large internal diameter, welding beads or through pipe ends.

Crushing strength:

The maximum operating pressure and test pressure is not only dependent on the burst pressure of the rubber bellow, but can also be affected by operating temperature, as well as design and nominal pressure of the flanges applied. The cold water burst pressure lies between 65 and 90 bar (min. safety factor 1:4), according to the assembly length, size and limiters. With tie rods higher burst pressures are achieved. Certificates for pressure tests with water can be issued against extra charge.

Vacuum Resistance:

The permitted vacuum resistance depends on size, operating temperature, installation length and eventually installed vacuum support rings. The maximum vacuum can be somewhat increased even without vacuum support rings, if the installation length is shortened (e.g. around 20 mm). However, the vacuum resistance is reduced when a longer installation length is chosen or the expansion joint is lengthened during operation.

Resistance against weathering and heat:

The outer rubber is weatherproof and protects the reinforcements against ageing, wear and tear as well as corrosion. The bellow is usable down to approx. -30°C and can be used in tropical conditions. The permitted maximum temperature of each ERV type is stated in its technical specification. When subjected to continuously hot temperatures over 50°C performance decreases, depending on operational pressure, maximum vacuum and range of movement. For permitted service conditions of type Yellow, Red, Green, White and CR. For estimated service life with maintained high temperature and external radiation heat. The outer rubber of ERV types Yellow, Green and White is flame resistant and, within limits, oil proof. An additional flame protection can be achieved by using a flame protection type conforming to the standard of "Germanischer Lloyd" 1-11.

Pressure drop:

The internal design of ERV bellows avoids turbulences. Even with high flow rates the pressure drop is negligible. The insertion of additional conduit tubes or pipe sleeves only would be disadvantageous.

Noise reduction:

Due to their design, ERV expansion joints reduce the sound conducted through fluids and solids within pipeworks. If the total installing length is shortened by between 5 and 10 mm noise damping can be further improved. Installation length / installation. If possible, do plan with the recommended installation length or slightly shorter. The low inherent resistance of the ERV allows compression by hand and eases fitting into short installation gaps. For larger installation or lateral offset not more than 50% of the maximum movement range should be utilized in order to leave a reserve for operation. For bellow extensions during operation, a jolted installation is recommended. The position of installation must be accessible for visual examination. When installing the unit the installation instructions must be observed.

Fixed point load / limiters (tie rods):

The inherent resistance of ERV bellows is negligible in respect to calculations for anchorage points. Under pressure the bellow acts like a plunger, hence requiring to fix anchorage points for larger size expansion joints. Since the construction of most ERV types absorb part of the reaction forces, anchorage points may be correspondingly weaker. If such anchorage points are not provided or the stability of the other fittings is insufficient reaction forces have to be absorbed by tie rods.

Marking and identification:

Each ERV is marked with a permanent vulcanized coloured band and identification stamp, showing type, nominal width DN, manufacturers mark, nominal pressure PN as well as the manufacturing date.

1. RIGHT

Flanges with correct ID help prevent damage to rubber

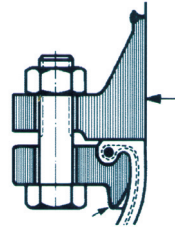

2. WRONG

Flanges with too large internal diameter can damage rubber

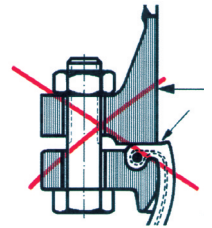

3. RIGHT

Weld neck flanges with correct ID prevent damage to rubber

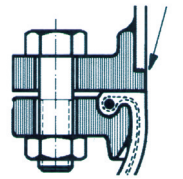

4. WRONG

Uneven end of pipe can cause damage to rubber

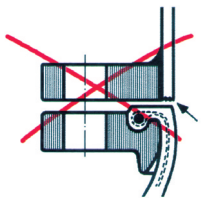

5. RIGHT

Additional flat packing can be used to prevent damage to rubber

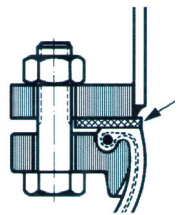

6. WRONG

Inner edge of flanges damages rubber

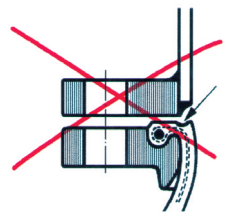

7. RIGHT

Well rounded smooth edge prevents damage to rubber

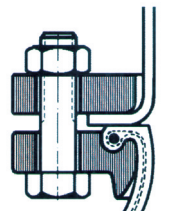

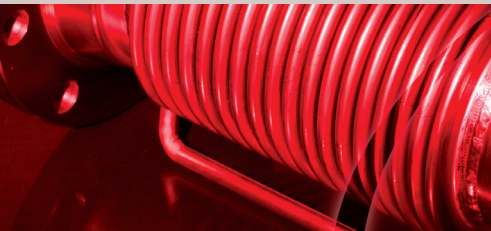

Teddington Unrestrained Bellows Expansion Joints

Unrestrained Bellows Expansion Joints as described in this brochure are NOT pressure restrained along their longitudinal axis and so the provision of an adequate pipeline guiding and anchoring system is necessary to absorb the pipeline loads and to control the direction of the pipeline movement.

In this regard we strongly recommend that reference is made to the "Users Guide to Teddington Bellows"* prior to any installation.

Whilst every effort has been made to ensure that the information contained in this brochure is correct, Teddington Bellows Ltd cannot be held responsible for any inaccuracies herein. We also reserve the right to change specifications without prior notice.

Unit Type

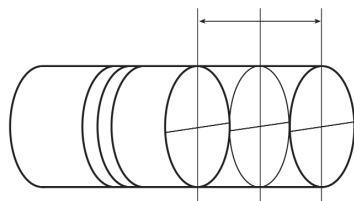

- **AXIAL** - in which compression and extension movements are accommodated along the bellows' longitudinal axis.

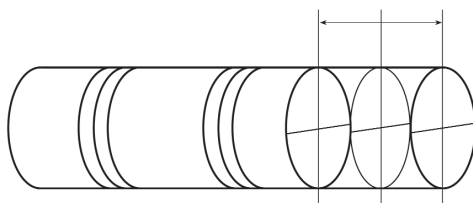

- **UNIVERSAL** - in which Axial together with lateral (transverse) movements are accommodated along the bellows' longitudinal and transverse axis.

* Users Guide to Teddington Bellows - available on request

How to Specify

Any unit detailed in the following Data Sheets can be specified by quoting the following information in its Coded form.

UNIT TYPE	NOMINAL SIZE	TOTAL MOVEMENT	END FITTINGS	ACCESSORIES
The type of unit available is indicated in the top right hand corner of each Data Sheet. <i>Example:</i> An Axial Unit suitable for a working pressure of 6 Bar would be specified as	The nominal size of units available are shown in the first column of each Data Sheet. <i>Example:</i> Assuming pipeline being considered is 300mm nominal diameter, then this would be specified as	Having determined the movement to be accommodated by each unit, select the nearest appropriate movement from the range available. <i>Example:</i> Assuming 300mm nominal diameter pipeline with a movement requirement of 65mm, then nearest specified would be	The standard end fittings available with code are shown in the table below. <i>Example:</i> Should you require unit flanged to BS 4504 - Table 6, then this would be specified as	The specified code for accessories is as follows: 0 - no accessories required 1 - internal sleeve required 2 - external shroud required 3 - internal sleeve & external shroud required <i>Example:</i> Should you require unit with internal sleeve, then this would be specified as
AR6	300	70	006	1

The complete code would now be written as AR6/300/70/006/1

End Fitting	Pipe Flange	Code
AR1	BSMA9	000
AR 3.5	BS10 - Table A	001
	BS10-Table D	002
AR6	BS10 - Table E	003
	ASA 150	150
	BS 4504 - Table 6	006
AR10	BS10 -Table F	004
	ASA 150	150
	BS 4504 - Table 10	010
AR16	BS10 -Table H	005
	ASA 300	300
	BS4504 - Table 16	016
AR25	BS10 - Table H	005
	ASA 300	300
	BS 4504 - Table 25	025
UD2	BS10 -Table A	001
	BS10 -Table D	002
	BS 4504 - Table 6	006
Ado	BS10 -Table E	003
	BS4504-Table 6	006

End Fitting	Pipe Ends	Code
AR1	BS MA9	401
UD2	DIN 2458/BS1600	
	Part 2 Standard Wall	402
AR 3.5	BS 1600 Part 2 Standard Wall	403
AC 7	Copper	404
AX16	DIN 2458	405
AR 25	DIN 2458	406

End Fitting	Threaded Unions	Code
AS 10	BS 1740	501

UNIT TYPE

AR1

Axial Unit with Flanges

Axial Unit with Flanges

- Working pressure
1 bar gauge maximum
- Working temperature
480°C maximum
- Test pressure
1.5 bar gauge

End fittings

- BS MA9

Materials

- Bellows
Stainless steel, type 321
- Internal sleeves
Stainless steel, type 321
- Flanges
Carbon steel

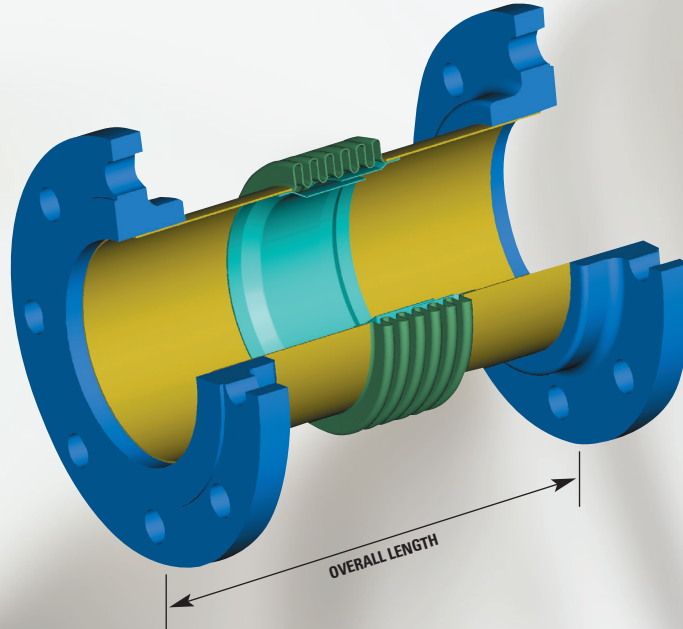

NOMINAL SIZE	MOVEMENT		OVERALL LENGTH		FLANGE DETAILS			EFFECTIVE AREA	AXIAL SPRING RATE
	+ and -	TOTAL	SUPPLIED L	INSTALLED *	O/D	No OF HOLES	P.C.D		
mm	mm	mm	mm	mm	mm		mm	cm ²	N/mm
300	25 50	50 100	185 230	210 280	440	12	395	967	85 45
350	25 50	50 100	190 235	215 285	490	12	445	1171	105 55
400	25 50	50 100	190 235	215 285	540	16	495	1498	120 60
450	30 60	60 120	230 285	260 345	595	16	550	1919	160 80
500	30 60	60 120	230 285	260 345	645	20	600	2332	180 90
550	30 60	60 120	230 285	260 345	692	20	645	2814	190 100
600	30 60	60 120	230 285	260 345	742	20	695	3281	200 100
650	30 60	60 120	230 285	260 345	792	20	745	3580	220 110
700	35 70	70 140	230 285	265 355	842	24	795	4551	300 150
750	35 70	70 140	230 285	265 355	893	24	845	5177	320 160
800	35 70	70 140	230 285	265 355	948	24	900	5844	340 170
850	35 70	70 140	230 285	265 355	998	28	950	6514	360 180
900	35 70	70 140	230 285	265 355	1048	28	1000	7297	380 190
950	35 70	70 140	230 285	265 355	1098	28	1050	8131	400 200
1000	35 70	70 140	230 285	265 355	1148	32	1100	8905	420 210
1050	35 70	70 140	230 285	265 355	1198	32	1150	9777	440 220
1100	35 70	70 140	230 285	265 355	1253	32	1205	10690	460 230
1150	35 70	70 140	230 285	265 355	1303	36	1255	11266	460 230
1200	35 70	70 140	230 285	265 355	1353	36	1305	12640	500 250

Notes

1. For unit sizes or operating conditions outside of the range specified above, please refer to Teddington Bellows.
2. For units above Nominal Size 12 inch (300mm Nom., flanged to BS10: 1962, the nominal size as shown in column 1 of the above table refers to the outside diameter of the line pipe. It follows that in accordance with BS10: 1962 a 16 inch nominal size (400mm Nom) would have a flange size designation of 15 inches.

* Installed length shown assumes total movement applied in compression.

Axial Unit with Flanges

UNIT TYPE

AR3.5

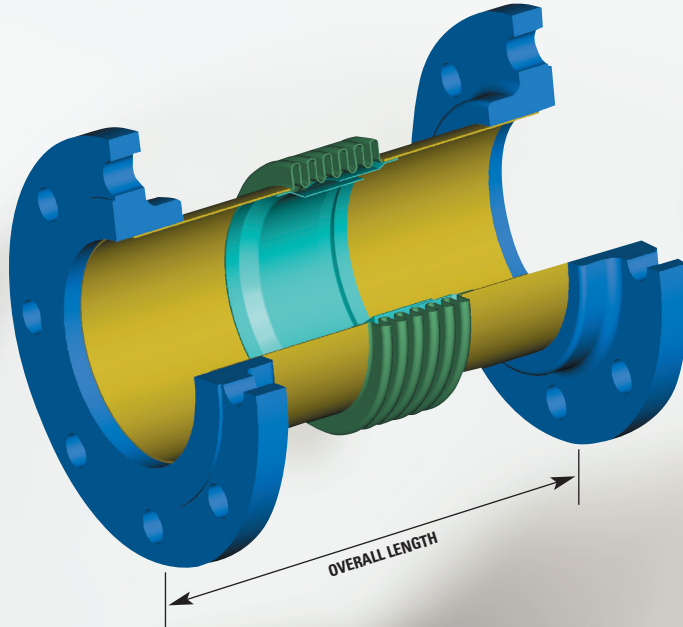

Axial Unit with Flanges

- Working pressure
3.5 bar gauge maximum
- Working temperature
300°C maximum
- Test pressure
5.25 bar gauge

End fittings

- Flanges
(300 to 600 Nom.) BS10 - Table D (700 to 1200 Nom.)
BS10 -Table A (All sizes)
BS4504-Table 6

Materials

- Bellows
Stainless steel, type 321
- Internal sleeves
Stainless steel, type 321
- Flanges
Carbon Steel

NOMINAL SIZE	MOVEMENT		OVERALL LENGTH		EFFECTIVE AREA	AXIAL SPRING RATE
	+ and -	TOTAL	SUPPLIED L	INSTALLED *		
mm	mm	mm	mm	mm	cm ²	N/mm
300	25	50	190	215	988	150
	50	100	250	300		75
350	25	50	222	247	1194	180
	50	100	318	368		90
400	25	50	230	255	1524	200
	50	100	330	380		100
450	25	50	230	255	1957	340
	50	100	330	380		170
500	25	50	230	255	2374	380
	50	100	330	380		190
600	25	50	240	265	3330	450
	50	100	336	386		225
700	25	50	250	275	4447	710
	50	100	344	394		355
750	25	50	260	285	5067	760
	50	100	355	405		380
800	25	50	260	285	5727	800
	50	100	355	405		400
900	25	50	285	310	7169	900
	50	100	380	430		450
1000	30	60	285	315	8773	700
	60	120	380	440		350
1050	30	60	300	330	9636	740
	60	120	394	454		370
1100	30	60	300	330	11000	780
	60	120	394	454		390
1200	30	60	310	340	12470	840
	60	120	406	466		420

Notes

1. For unit sizes or operating conditions outside of the range specified above, please refer to Teddington Bellows.
2. For units above Nominal Size 12 inch (300mm Nom., flanged to BS10: 1962, the nominal size as shown in column 1 of the above table refers to the outside diameter of the line pipe. It follows that in accordance with BS10: 1962 a 16 inch nominal size (400mm Nom) would have a flange size designation of 15 inches.

* Installed length shown assumes total movement applied in compression.

UNIT TYPE

AR6

Axial Unit with Flanges

Axial Unit with Flanges

- Working pressure
6 bar gauge maximum
- Working temperature
300°C maximum
- Test pressure
10 bar gauge

End fittings

- Flanges
BS10 - Table E, ASA 150,
BS4504 - Table 6

Materials

- Bellows
Stainless steel, type 321
- Internal sleeves
Stainless steel, type 321
- Flanges
Carbon steel

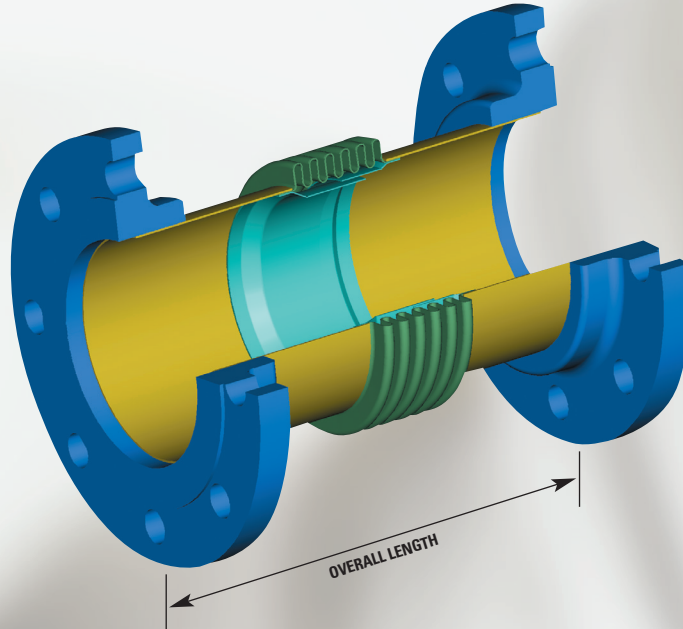

NOMINAL SIZE	MOVEMENT		OVERALL LENGTH: SUPPLIED L / * INSTALLED						EFFECTIVE AREA	AXIAL SPRING RATE
	+ and -	TOTAL	BS4504 L	TABLE 6 *	BS10 L	TABLE E *	ASA 150 L	*		
mm	mm	mm	mm	mm	mm	mm	mm	mm	cm ²	N/mm
20	12.5	25	232	244.5	178	190.5	273	285.5	19	50
	25	50	299	324	244	269	340	369		
25	12.5	25	238	250.5	178	190.5	279	291.5	19	50
	25	50	305	330	244	269	346	371		
32	12.5	25	137	149.5	108	120.5	181	193.5	19	50
	25	50	201	226	170	195	246	271		
40	19	38	147	159.5	110	122.5	195	207.5	22	60
	25	50	212	237	175	200	260	285		
50	20	40	170	190	140	160	225	245	37	40
	30	60	225	255	190	220	275	305		
65	22.5	45	180	202.5	150	172.5	240	262.5	56	50
	35	70	225	260	200	235	290	325		
80	30	60	200	230	165	195	255	285	80	40
	55	110	300	355	265	320	355	410		
100	30	60	205	235	175	205	265	295	126	55
	55	110	305	360	275	330	370	425		
125	30	60	225	255	190	220	305	335	192	90
	55	110	340	395	310	365	425	480		
150	30	60	225	255	200	230	305	365	226	110
	55	110	340	395	315	370	425	480		
200	30	60	240	270	205	235	335	365	447	175
	60	120	365	425	335	395	360	420		
250	30	60	250	280	220	250	220	250	663	225
	60	120	390	450	360	420	360	420		
300	35	70	265	300	240	275	245	280	988	365
	62.5	125	385	447.5	360	422.5	365	427.5		
350	35	70	250	285	260	295	280	315	1194	275
	62.5	125	355	417.5	350	412.5	370	432.5		
400	35	70	255	290	275	310	285	320	1524	315
	62.5	125	360	422.5	400	462.5	410	472.5		
450	35	70	258	293	310	345	320	355	1957	210
	75	150	415	490	465	540	475	550		
500	35	70	265	300	315	350	325	360	2374	570
	75	150	420	495	470	545	475	550		
600	35	70	265	300	335	370	345	380	3330	685
	75	150	420	495	490	565	495	570		

Notes

1. For unit sizes or operating conditions outside of the range specified above, please refer to Teddington Bellows.
2. For units above Nominal Size 12 inch (300mm Nom., flanged to BS10: 1962, the nominal size as shown in column 1 of the above table refers to the outside diameter of the line pipe. It follows that in accordance with BS10: 1962 a 16 inch nominal size (400mm Nom) would have a flange size designation of 15 inches.

* Installed length shown assumes total movement applied in compression

Axial Unit with Flanges

UNIT TYPE

AR10

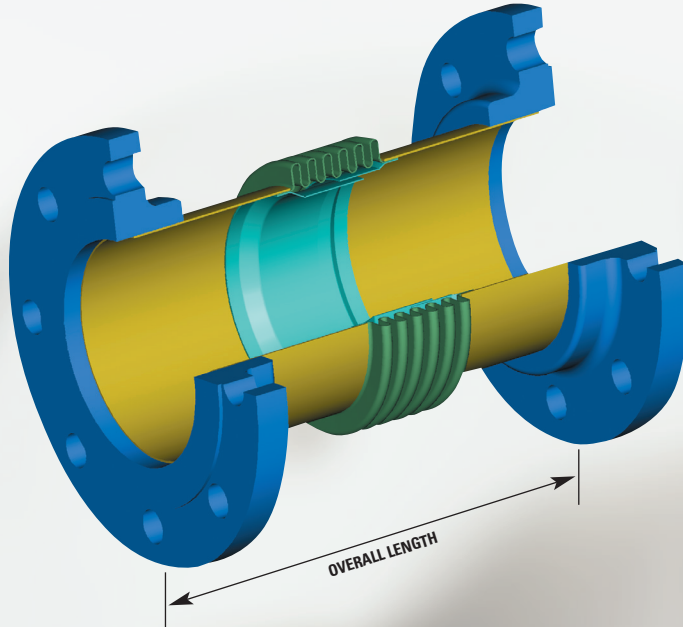

Axial Unit with Flanges

- Working pressure
10 bar gauge maximum
- Working temperature
300°C maximum
- Test pressure
15 bar gauge

End fittings

- Flanges
BS10 - Table F, ASA 150,
BS4504 - Table 10

Materials

- Bellows
Stainless steel, type 321
- Internal sleeves
Stainless steel, type 321
- Flanges
Carbon steel

NOMINAL SIZE	MOVEMENT		OVERALL LENGTH: SUPPLIED L / * INSTALLED						EFFECTIVE AREA	AXIAL SPRING RATE
	+ and -	TOTAL	BS 4504 L	TABLE 10 *	BS10 L	TABLE F *	ASA 150 L	*		
mm	mm	mm	mm	mm	mm	mm	mm	mm	cm ²	N/mm
20	12.5	25	244	256.5	178	190.5	273	285.5	19	50
	25	50	311	336	244	269	340	365		
25	12.5	25	244	256.5	178	190.5	279	291.5	19	50
	25	50	311	336	244	269	346	371		
32	12.5	25	147	159.5	117	129.5	181	193.5	19	50
	25	50	211	236	181	206	246	271		
40	19	38	155	167.5	124	136.5	195	207.5	22	60
	25	50	220	245	190	215	260	285		
50	20	40	185	205	155	175	225	245	37	60
	30	60	250	280	215	245	285	315		
65	22.5	45	195	217.5	165	187.5	245	267.5	56	70
	35	70	250	285	225	260	300	335		
80	25	50	215	240	175	200	255	280	80	65
	50	100	335	385	290	340	370	410		
100	30	60	235	265	205	235	285	315	126	75
	55	110	335	390	305	360	385	440		
125	30	60	240	270	205	235	305	335	192	135
	55	110	375	430	345	400	445	500		
150	30	60	240	270	205	235	305	335	266	175
	55	110	375	430	345	400	445	500		
200	30	60	265	295	230	260	345	375	447	250
	55	110	360	415	325	380	440	495		
250	30	60	275	305	245	275	235	265	663	390
	60	120	415	475	385	445	370	430		
300	35	70	285	320	265	300	255	290	988	660
	62.5	125	400	462.5	375	437.5	365	427.5		
350	35	70	270	305	315	350	315	350	1194	385
	62.5	125	385	447.5	465	527.5	465	527.5		
400	35	70	280	315	330	365	330	365	1524	525
	62.5	125	390	452.5	425	487.5	475	537.5		
450	35	70	282	317	350	385	345	380	1957	720
	75	150	446	521	515	590	510	585		
500	35	70	290	325	345	380	345	380	2374	805
	75	150	450	525	510	585	510	585		
600	35	70	300	335	385	420	370	405	3330	970
	75	150	465	540	550	625	535	610		

Notes

1. For unit sizes or operating conditions outside of the range specified above, please refer to Teddington Bellows.
2. For units above Nominal Size 12 inch (300mm Nom., flanged to BS10: 1962, the nominal size as shown in column 1 of the above table refers to the outside diameter of the line pipe. It follows that in accordance with BS10: 1962 a 16 inch nominal size (400mm Nom) would have a flange size designation of 15 inches.

* Installed length shown assumes total movement applied in compression.

UNIT TYPE

AR16

Axial Unit with Flanges

Axial Unit with Flanges

- Working pressure
16 bar gauge maximum
- Working temperature
300°C maximum
- Test pressure
24 bar gauge

End fittings

- Flanges
BS10 - Table H, ASA 300,
BS4504 - Table 16

Materials

- Bellows
Stainless steel, type 321
- Internal sleeves
Stainless steel, type 321
- Flanges
Carbon steel

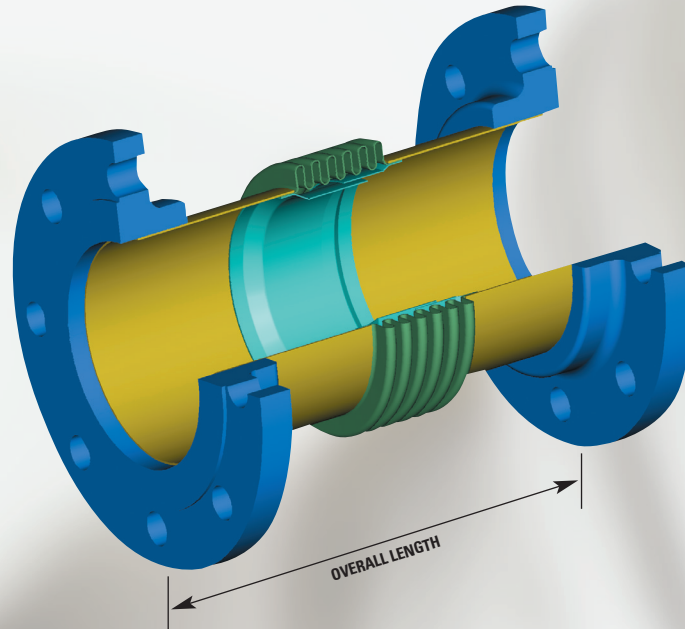

NOMINAL SIZE	MOVEMENT		OVERALL LENGTH: SUPPLIED L / * INSTALLED						EFFECTIVE AREA	AXIAL SPRING RATE
	+ and -	TOTAL	BS4504 L	TABLE 16 *	BS10 L	TABLE H *	ASA 300 L	ASA 300 *		
mm	mm	mm	mm	mm	mm	mm	mm	mm	cm ²	N/mm
20	12.5	25	254	266.5	187	199.5	290	302.5	19	65
	25	50	324	349	257	282	360	385		
25	12.5	25	254	266.5	187	199.5	300	312.5	19	65
	25	50	324	349	257	282	370	395		
32	12.5	25	155	167.5	133	145.5	205	217.5	19	65
	25	50	226	251	203	228	275	300		
40	12.5	25	160	172.5	136	148.5	215	227.5	22	75
	25	50	230	255	206	231	280	305		
50	20	40	180	200	150	170	155	175	37	60
	30	60	265	295	225	255	225	255		
65	22.5	45	190	212.5	165	187.5	170	192.5	56	95
	35	70	265	300	240	275	250	285		
80	25	50	220	245	195	220	205	230	80	90
	50	100	350	400	325	375	335	385		
100	30	60	225	255	210	240	215	245	126	160
	55	110	355	410	340	395	345	400		
125	30	60	260	290	240	270	250	280	192	150
	55	110	395	450	375	430	385	440		
150	30	60	260	290	240	270	250	280	266	180
	55	110	395	450	375	430	385	440		
200	30	60	275	305	255	285	270	300	447	300
	55	110	405	460	385	440	400	455		
250	30	60	290	320	270	300	280	310	663	380
	55	110	420	475	400	455	410	465		
300	35	70	335	370	315	350	320	355	988	550
	62.5	125	475	537.5	455	517.5	460	522.5		
350	35	70	350	385	395	430	415	450	1194	580
	62.5	125	465	527.5	510	572.5	525	587.5		
400	35	70	355	390	415	450	425	460	1524	670
	62.5	125	475	537.5	525	587.5	550	612.5		
450	35	70	350	385	415	450	420	455	1957	745
	62.5	125	467	529.5	530	592.5	535	597.5		
500	35	70	355	390	425	460	425	460	2374	830
	62.5	125	475	537.5	545	607.5	545	607.5		
600	35	70	365	400	470	505	455	490	3330	1000
	62.5	125	480	542.5	585	647.5	575	637.5		

Notes

1. For unit sizes or operating conditions outside of the range specified above, please refer to Teddington Bellows.
2. For units above Nominal Size 12 inch (300mm Nom., flanged to BS10: 1962, the nominal size as shown in column 1 of the above table refers to the outside diameter of the line pipe. It follows that in accordance with BS10: 1962 a 16 inch nominal size (400mm Nom) would have a flange size designation of 15 inches.

* Installed length shown assumes total movement applied in compression.

Axial Unit with Flanges

UNIT TYPE

AR25

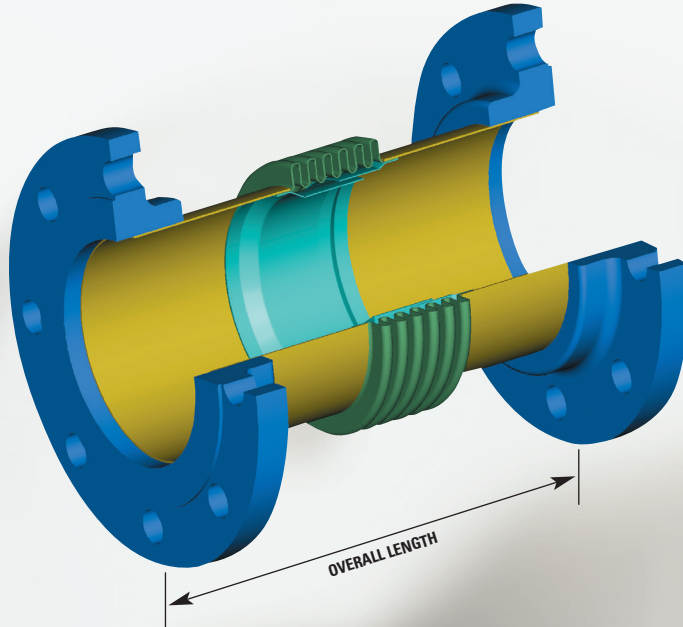

Axial Unit with Flanges

- Working pressure
25 bar gauge maximum
- Working temperature
300°C maximum
- Test pressure
37.5 bar gauge

End fittings

- Flanges
BS10 - Table H, ASA 300,
BS4504 - Table 25

Materials

- Bellows
Stainless steel, type 321
- Internal sleeves
Stainless steel, type 321
- Flanges
Carbon steel

NOMINAL SIZE	MOVEMENT		OVERALL LENGTH: SUPPLIED L / * INSTALLED						EFFECTIVE AREA	AXIAL SPRING RATE
	+ and -	TOTAL	BS4504 L	TABLE 25 *	BS10 L	TABLE H *	ASA 300 L	ASA 300 *		
mm	mm	mm	mm	mm	mm	mm	mm	mm	cm ²	N/mm
50	12.5	25	175	187.5	140	152.5	140	152.5	37	105
	24	48	255	279	225	249	225	249		
65	12.5	25	190	202.5	155	167.5	160	172.5	56	125
	24	48	265	289	230	254	235	259		
80	15	30	220	235	180	195	190	205	80	150
	30	60	330	360	295	325	300	330		
100	15	30	235	250	190	205	200	215	126	200
	30	60	345	375	305	335	310	340		
125	22.5	45	280	302.5	235	257.5	240	262.5	192	215
	45	90	430	475	385	430	390	435		
150	22.5	45	290	312.5	235	257.5	240	262.5	266	260
	45	90	440	485	385	430	390	435		
200	22.5	45	300	322.5	245	267.5	260	282.5	447	470
	45	90	455	500	395	440	415	460		
250	22.5	45	320	342.5	260	282.5	270	292.5	663	590
	45	90	470	515	410	455	420	465		
300	30	60	370	400	320	350	325	355	988	805
	40	80	425	465	365	405	380	420		
350	30	60	375	405	380	410	455	485	1194	815
	45	90	450	495	455	500	535	590		
400	30	60	395	425	400	430	465	495	1524	935
	45	90	475	520	475	520	540	585		
450	30	60	395	425	415	445	490	520	1957	1055
	45	90	475	520	490	535	570	615		
500	30	60	425	455	450	480	510	540	2374	1175
	45	90	500	545	525	570	585	630		
600	30	60	425	455	470	500	525	555	3330	1415
	45	90	500	545	545	590	605	650		

Notes

1. For unit sizes or operating conditions outside of the range specified above, please refer to Teddington Bellows.
2. For units above Nominal Size 12 inch (300mm Nom., flanged to BS10: 1962, the nominal size as shown in column 1 of the above table refers to the outside diameter of the line pipe. It follows that in accordance with BS10: 1962 a 16 inch nominal size (400mm Nom) would have a flange size designation of 15 inches.

* Installed length shown assumes total movement applied in compression.

UNIT TYPE

UD2

Unrestrained Double Unit with Flanges

Unrestrained double unit with flanges

- Working pressure
2 bar gauge maximum
- Working temperature
300°C maximum
- Test pressure
3 bar gauge

End fittings

- (50 to 600 Nom.) BS10 - Table D, (700 to 800 Nom.) BS10 - Table A (All sizes) 8S4504 - Table 6

Materials

- Bellows
Stainless steel, type 321
- Internal sleeves
Stainless steel, type 321
- Centre tube
Stainless steel, type 321
- Flanges
Carbon Steel

Notes on combination movements

By referring to above tables you can establish:

1. ± Axial movement available
2. ± Lateral movement available

The following simple law applies:

$$(a) \frac{Reqd \pm Axial}{Available \pm Axial} + \frac{Reqd \pm Lateral}{Available \pm Axial} \leq 1$$

Should this formula equate to a figure greater than 1, provided the axial ratio is less than 1 the extra lateral movement required can be obtained by increasing the bellows centres. This value can be calculated by the following formula:

$$(b) \frac{Lateral \ ratio \times \ Bellows \ centres}{1 - Axial \ ratio}$$

By necessity this would increase the overall length of the unit by the same amount as the Bellows centres is increased.

Note

Should formula (a) equate to a figure less than 1, then formula (b) can be used to calculate the required bellows centres. As the lateral rate is dependent upon the bellows centres, any alteration in that distance shown in the table will give a new lateral rate, which can be calculated from the following formula:

$$\left(\frac{Original \ bellows \ centres}{New \ bellows \ centres} \right)^2 \times Original \ Lateral \ rate$$

Please see example in Glossary.

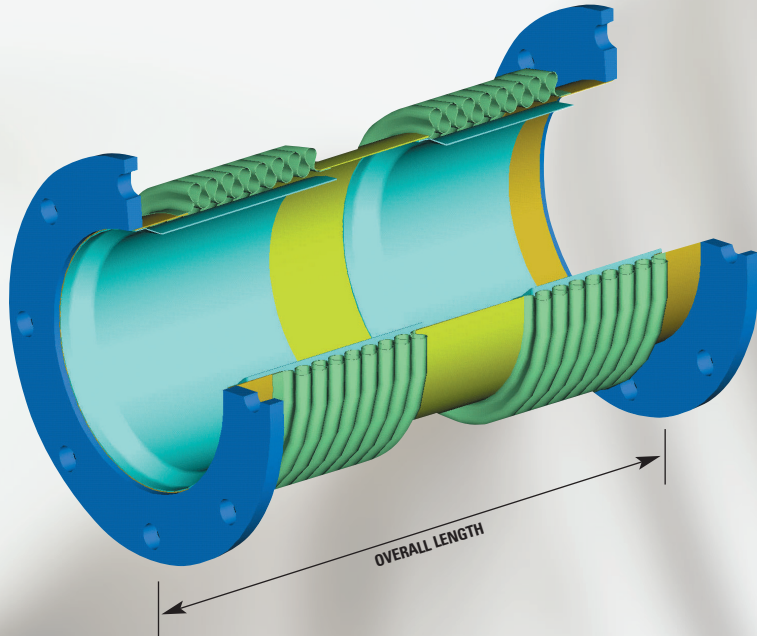

NOMINAL SIZE	MOVEMENT					BELLOWS CENTRE	OVERALL LENGTH SUPPLIED L	EFFECTIVE AREA	SPRING RATE	
	+ and - AXIAL ONLY	TOTAL AXIAL ONLY	+ and - LATERAL ONLY	ALT COMBINATION					AXIAL	LATERAL
				+ and - AXIAL	+ and - LATERAL					
mm	mm	mm	mm	mm	mm	mm	cm ²	N/mm	N/mm	
50	18	36	65	10	30	330	480	37	30	5
65	18	36	65	10	30	330	490	56	35	5
80	24	48	65	12	30	330	500	80	25	5
100	24	48	65	12	30	335	500	126	30	5
125	45	90	65	18	30	255	475	192	35	10
150	45	90	65	18	30	255	475	266	45	10
200	58	116	65	22	30	305	515	447	60	20
250	58	116	65	22	30	355	610	663	70	25
300	60	120	65	22	30	405	675	988	125	45
350	65	130	65	25	40	460	735	1194	90	35
400	65	130	65	25	40	460	735	1524	100	45
450	78	156	65	25	45	460	780	1957	140	85
500	78	156	65	25	45	535	860	2374	155	85
600	78	156	65	25	45	585	900	3330	185	115
700	78	156	65	25	45	660	1010	4447	210	135
750	78	156	65	25	45	700	1025	5067	225	145
800	78	156	65	25	45	740	1090	5727	240	160

Unrestrained Double Unit with Pipe Ends

UNIT TYPE

UD2

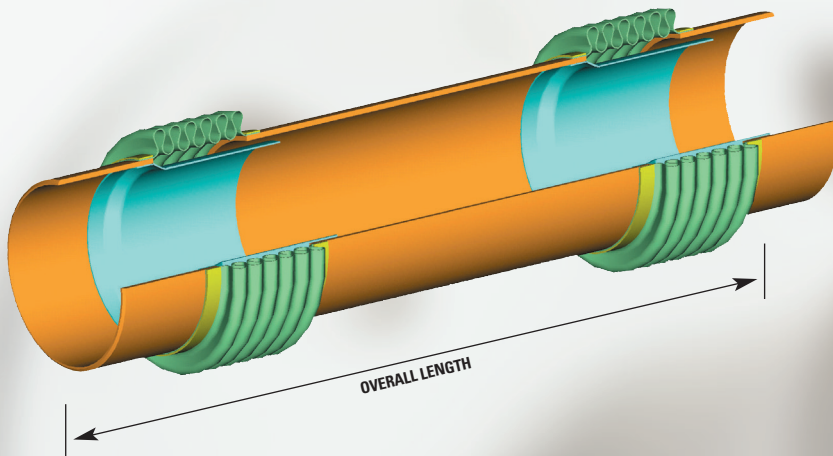

Unrestrained Double Unit with Pipe Ends

- Working pressure
2 bar gauge maximum
- Working temperature
300°C maximum
- Test pressure
3 bar gauge

End fittings

- Pipe ends (50 to 300 Nom.) DIN 2458, (300 to 800 Nom.) BS1600 Part 2, Std. Wall

Materials

- Bellows
Stainless steel, type 321
- Internal sleeves
Stainless steel, type 321
- Centre tube
Stainless steel, type 321
- Pipe ends
Carbon Steel

NOMINAL SIZE	MOVEMENT					BELLOWS CENTRE	OVERALL LENGTH SUPPLIED L	EFFECTIVE AREA	SPRING RATE	
	+ and - AXIAL ONLY	TOTAL AXIAL ONLY	+ and - LATERAL ONLY	ALT COMBINATION					AXIAL	LATERAL
				+ and - AXIAL	+ and - LATERAL					
mm	mm	mm	mm	mm	mm	mm	mm	cm ²	N/mm	N/mm
50	18	36	65	10	30	330	480	37	30	5
65	18	36	65	10	30	330	490	56	35	5
80	24	48	65	12	30	330	500	80	25	5
100	24	48	65	12	30	335	500	126	30	5
125	45	90	65	18	30	255	475	192	35	10
150	45	90	65	18	30	255	475	266	45	10
200	58	116	65	22	30	305	515	447	60	20
250	58	116	65	22	30	355	610	663	70	25
300	60	120	65	22	30	405	675	988	125	45
350	65	130	65	25	40	460	735	1194	90	35
400	65	130	65	25	40	460	735	1524	100	45
450	78	156	65	25	45	460	780	1957	140	85
500	78	156	65	25	45	535	860	2374	155	85
600	78	156	65	25	45	585	900	3330	185	115
700	78	156	65	25	45	660	1010	4447	210	135
750	78	156	65	25	45	700	1025	5067	225	145
800	78	156	65	25	45	740	1090	5727	240	160

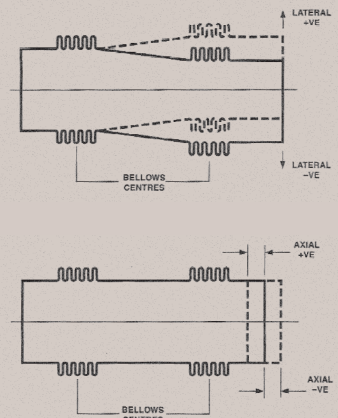

Notes

1. For unit sizes or operating conditions outside of the range specified above, please refer to Teddington Bellows.
2. For units above Nominal Size 12 inch (300mm Nom., flanged to BS10: 1962, the nominal size as shown in column 1 of the above table refers to the outside diameter of the line pipe. It follows that in accordance with BS10: 1962 a 16 inch nominal size (400mm Nom) would have a flange size designation of 15 inches.

UNIT TYPE

AR1

Axial Unit with Pipe Ends

Axial Unit with Pipe Ends

- Working pressure
1 bar gauge maximum
- Working temperature
480°C maximum
- Test pressure
1.5 bar gauge

End fittings

- Pipe ends

Materials

- Bellows
Stainless steel, type 321
- Internal sleeves
Stainless steel, type 321
- Pipe ends
Carbon steel

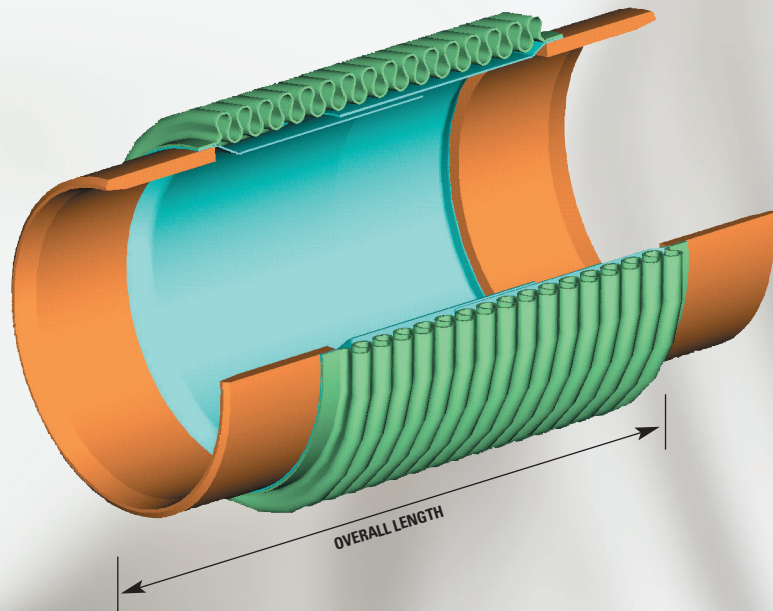

NOMINAL SIZE	MOVEMENT		OVERALL LENGTH		PIPE SIZE		MAX BELLOWS O/D	EFFECTIVE AREA	AXIAL SPRING RATE
	+ and -	TOTAL	SUPPLIED L	INSTALLED *	O/D	THK			
mm	mm	mm	mm	mm	mm	mm	mm	cm ²	N/mm
300	25	50	280	305	323.9	6.3	377	967	85
	50	100	355	405					
350	25	50	285	310	355.6	6.3	418	1171	105
	50	100	360	410					
400	25	50	285	310	406.4	6.3	469	1498	120
	50	100	360	410					
450	30	60	300	330	457	6.3	533	1919	160
	60	120	395	455					
500	30	60	300	330	508	6.3	584	2332	180
	60	120	395	455					
550	30	60	300	330	559	6.3	637	2814	190
	60	120	395	455					
600	30	60	300	330	610	6.3	685	3281	200
	60	120	395	455					
650	30	60	300	330	660	6.3	715	3580	220
	60	120	395	455					
700	35	70	300	335	711	6.3	813	4551	300
	70	140	395	465					
750	35	70	300	335	762	6.3	863	5177	320
	70	140	395	465					
800	35	70	300	335	813	6.3	914	5844	340
	70	140	395	465					
850	35	70	300	335	864	6.3	963	6514	360
	70	140	395	465					
900	35	70	300	335	914	6.3	1015	7297	380
	70	140	395	465					
950	35	70	300	335	965	6.3	1069	8131	400
	70	140	395	465					
1000	35	70	300	335	1016	6.3	1115	8905	420
	70	140	395	465					
1050	35	70	300	335	1065	6.3	1167	9777	440
	70	140	395	465					
1100	35	70	300	335	1120	6.3	1218	10690	460
	70	140	395	465					
1150	35	70	300	335	1170	6.3	1250	11266	460
	70	140	395	465					
1200	35	70	300	335	1220	6.3	1320	12640	500
	70	140	395	465					

Notes

1. For unit sizes or operating conditions outside of the range specified above, please refer to Teddington Bellows.
- * Installed length shown assumes total movement applied in compression.

Axial Unit with Pipe Ends

UNIT TYPE

AR3.5

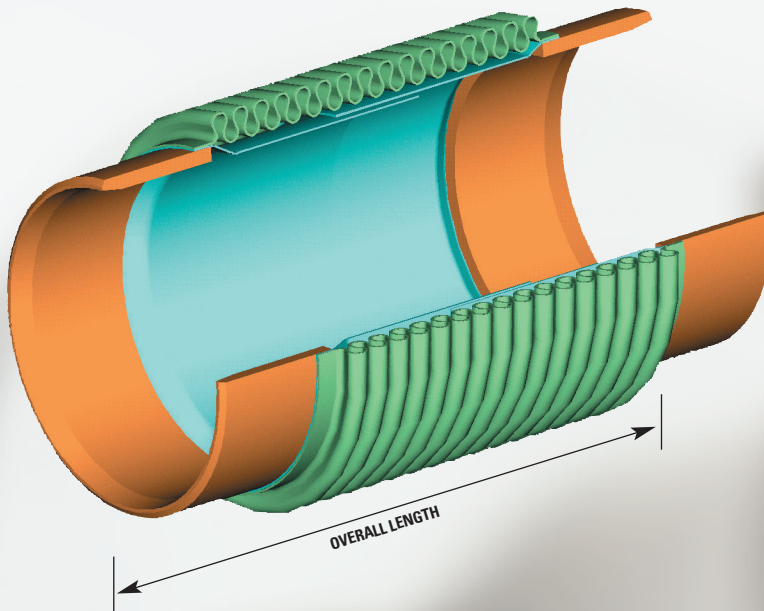

Axial Unit with Pipe Ends

- Working pressure
3.5 bar gauge maximum
- Working temperature
300°C maximum
- Test pressure
5.25 bar gauge

End fittings

- Pipe Ends
BS1600 part 2. std wall

Materials

- Bellows
Stainless steel, type 321
- Internal sleeves
Stainless steel, type 321
- Pipe ends
Carbon Steel

NOMINAL SIZE	MOVEMENT		OVERALL LENGTH		PIPE SIZE		MAX BELLOWS O/D	EFFECTIVE AREA	AXIAL SPRING RATE
	+ and -	TOTAL	SUPPLIED L	INSTALLED *	O/D	THK			
mm	mm	mm	mm	mm	mm	mm	mm	cm ²	N/mm
300	25 50	50 100	286 362	311 412	323.9	10	377	988	150 75
350	25 50	50 100	305 400	330 450	355.6	10	418	1194	180 90
400	25 50	50 100	305 400	330 450	406.4	10	469	1524	200 100
450	25 50	50 100	305 400	330 450	457.2	10	533	1957	340 170
500	25 50	50 100	350 445	375 495	508	10	584	2374	380 190
600	25 50	50 100	350 445	375 495	609.5	10	685	3330	450 225
700	25 50	50 100	350 445	375 495	711.2	10	813	4447	710 355
750	25 50	50 100	350 445	375 495	762	10	864	5067	760 380
800	25 50	50 100	350 445	375 495	812.8	10	915	5727	800 400
900	25 50	50 100	350 445	375 495	914.4	10	1016	7169	900 450
1000	30 60	60 120	360 470	390 530	1016	10	1118	8773	700 350
1050	30 60	60 120	360 470	390 530	1065	10	1169	9636	740 370
1100	30 60	60 120	360 470	390 530	1120	10	1220	11000	780 390
1200	30 60	60 120	360 470	390 530	1220	10	1321	12470	840 420

Notes

1. For unit sizes or operating conditions outside of the range specified above, please refer to Teddington Bellows.

* Installed length shown assumes total movement applied in compression.

UNIT TYPE

AX16

Axial Unit with Pipe Ends

Axial Unit with Pipe Ends

- Working pressure
16 bar gauge maximum
- Working temperature
300°C maximum
- Test pressure
24 bar gauge

End fittings

- Pipe ends
Din 2458

Materials

- Bellows
Stainless steel, type 321
- Internal sleeves
Stainless steel, type 321
- Pipe ends
Carbon steel

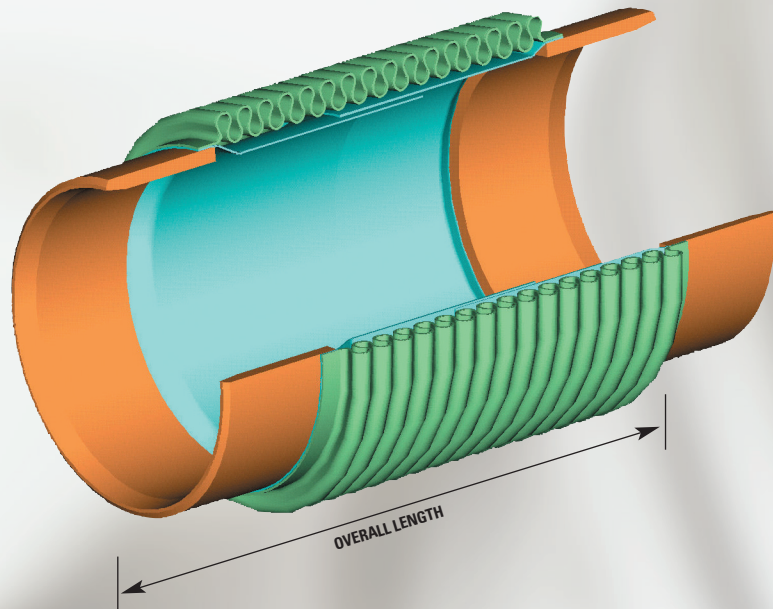

NOMINAL SIZE	MOVEMENT		OVERALL LENGTH		PIPE SIZE		MAX BELLOWS O/D	EFFECTIVE AREA	AXIAL SPRING RATE
	+ and -	TOTAL	SUPPLIED L	INSTALLED *	O/D	THK			
mm	mm	mm	mm	mm	mm	mm	mm	cm ²	N/mm
40	19 30	38 60	256 349	275 379	48.3	2.6	63	22.2	80 50
50	20 30	40 60	274 364	294 394	60.3	2.9	83	38	60 40
65	22.5 35	45 70	293 394	315.5 429	46.1	2.9	99	57.5	65 40
80	25 50	50 100	321 501	346 551	88.9	3.2	118	79.7	90 45
100	30 55	60 110	339 517	369 572	114.3	3.6	146	131	105 60
125	30 55	60 110	374 558	404 613	139.7	3.6	177	196	125 65
150	30 55	60 110	374 558	404 613	168.3	4	205	271	150 75
175	30 55	60 110	387 566	417 621	193.7	4	232	352	175 85
200	30 55	60 110	387 566	417 621	219.1	4.5	257	442	195 100
250	30 55	60 110	387 576	417 631	273	5	312	671	240 120
300	35 62.5	70 125	485 679	520 741.5	323.9	5.6	385	976	465 250
350	35 62.5	70 125	492 662	527 724.5	355.6	5.6	414	1139	505 270
400	35 62.5	70 125	497 667	532 729.5	406.4	6.3	464	1463	585 310
450	35 62.5	70 125	527 699	562 761.5	457.2	6.3	515	1827	655 350
500	35 62.5	70 125	537 708	572 770.5	508	6.3	566	2231	730 390
600	35 62.5	70 125	545 715	580 777.5	609.6	8	668	3162	880 470

Notes

1. For unit sizes or operating conditions outside of the range specified above, please refer to Teddington Bellows.
- * Installed length shown assumes total movement applied in compression.

Axial Unit with Pipe Ends

UNIT TYPE

AR25

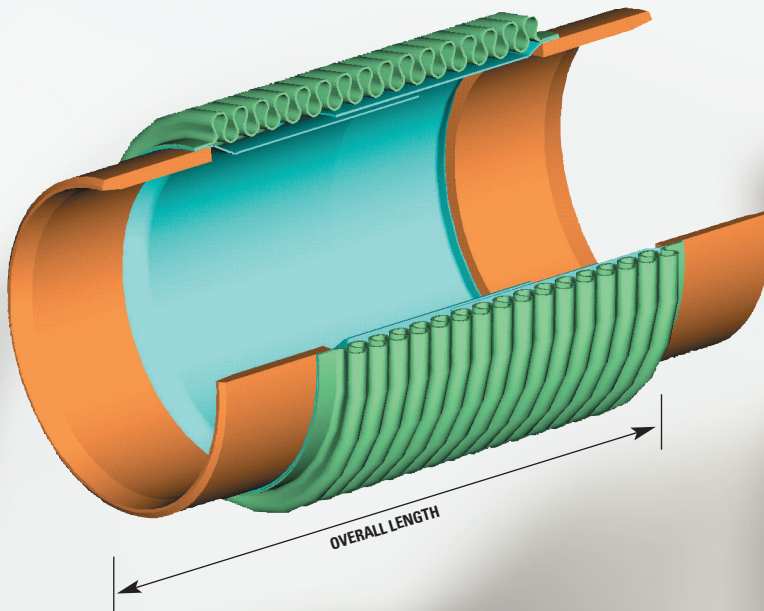

Axial Unit with Pipe Ends

- Working pressure
25 bar gauge maximum
- Working temperature
300°C maximum
- Test pressure
37.5 bar gauge

End fittings

- Pipe ends
Din 2458

Materials

- Bellows
Stainless steel, type 321
- Internal sleeves
Stainless steel, type 321
- Pipe ends
Carbon steel

NOMINAL SIZE	MOVEMENT		OVERALL LENGTH		PIPE SIZE		MAX BELLOWS O/D	EFFECTIVE AREA	AXIAL SPRING RATE
	+ and -	TOTAL	SUPPLIED L	INSTALLED *	O/D	THK			
mm	mm	mm	mm	mm	mm	mm	mm	cm ²	N/mm
40	10 20	20 40	190 255	200 275	48.3	2.9	59	20	130 65
50	12.5 24	25 48	220 300	232.5 324	60.3	2.9	80	37	105 55
65	12.5 24	25 48	225 300	237.5 324	76.1	2.9	96	56	130 65
80	15 30	30 60	225 370	270 400	88.9	3.2	115	80	150 75
100	15 30	30 60	255 370	270 400	114.3	3.6	144	126	200 100
125	22.5 45	45 90	310 460	332.5 505	139.7	4	176	192	220 110
150	22.5 45	45 90	310 460	332.5 505	168.3	4.5	204	266	270 135
175	22.5 45	45 90	320 470	342.5 515	193.7	5.4	238	357	420 210
200	22.5 45	45 90	320 470	342.5 515	219.1	6.2	264	447	470 235
250	22.5 45	45 90	320 470	342.5 515	273	6.3	319	663	600 300
300	30 40	60 80	390 445	420 485	323.9	7.1	385	988	810 620
350	30 45	60 90	380 455	410 500	355.6	8	430	1194	820 570
400	30 45	60 90	380 455	410 500	406.4	8.8	481	1524	940 650
450	30 45	60 90	430 505	460 550	457.2	10	532	1957	1060 740
500	30 45	60 90	430 505	460 550	508	10	583	2374	1180 820
600	30 45	60 90	430 505	460 550	609.6	11	684	3330	1420 990

Notes

1. For unit sizes or operating conditions outside of the range specified above, please refer to Teddington Bellows.

* Installed length shown assumes total movement applied in compression.

UNIT TYPE

AC7

Small Bore Axial Unit with Tube Ends

Small Bore Axial Unit with Tube Ends

- Suitable for copper hot water piping systems
- Working pressure 6 bar gauge maximum
- Working temperature 100°C maximum
- Test pressure 9 bar gauge

Materials

- Bellows Stainless steel, type 321
- Tube ends Copper
- Outer cover Plastic

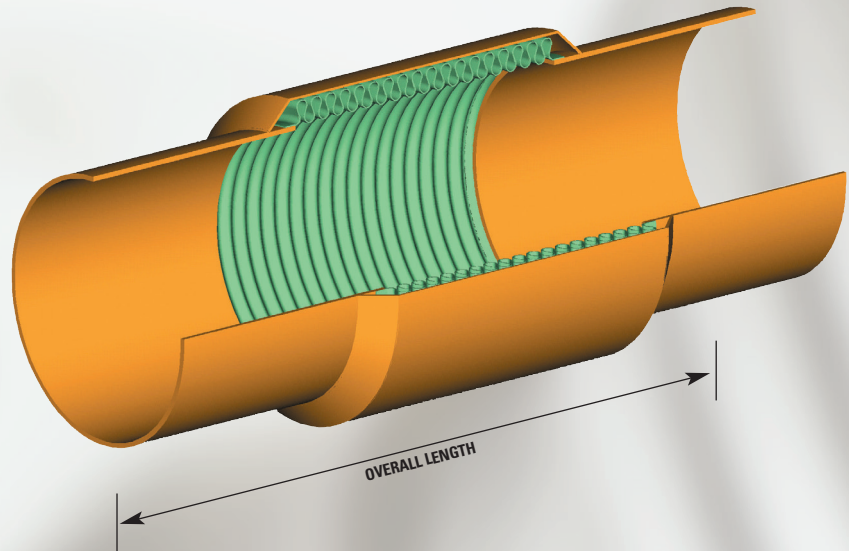

NOMINAL SIZE	MOVEMENT COMPRESSION ONLY	OVERALL LENGTH		MAX O/D OUTER COVER	MINIMUM ANCHOR LOAD AT TEST PRESSURE
		SUPPLIED L	INSTALLED *		
mm	mm	mm	mm	mm	kg
22	25	165	165	30	70
28	25	165	165	36	105
35	25	200	200	49	200
42	25	200	200	56	255

Notes

1. The AC7 unit is pre-set at the factory and suitable for the compression movement shown from the installed length and can be installed using either capillary or compression type fittings.
 2. For unit sizes or operating conditions outside of the range specified above, please refer to Teddington Bellows.
- * Installed length shown assumes total movement applied in compression.

Axial Unit with Flanges

UNIT TYPE

AC10

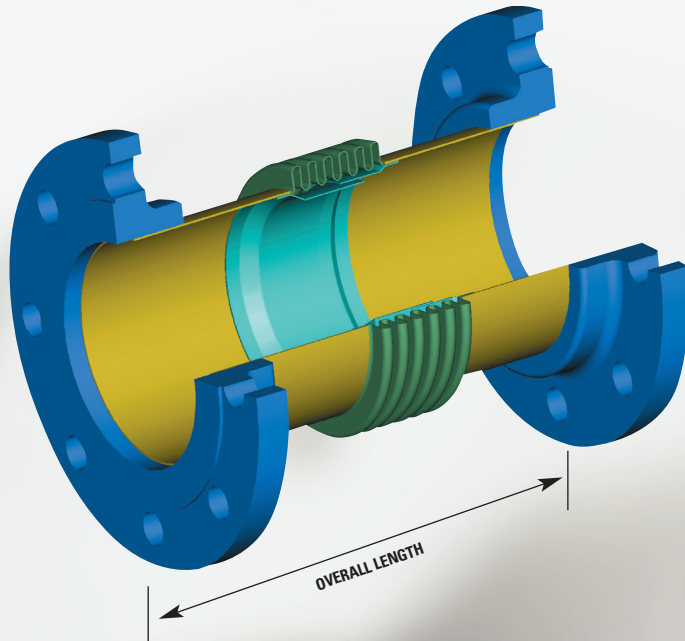

Axial Unit with Flanges

- Suitable for both copper and stainless steel hot water piping systems
- Working pressure 10 bar gauge maximum
- Working temperature 200°C maximum
- Test pressure 15 bar gauge

End fittings

- Flanges
BS10 - Table E,
BS4504 - Table 6

Materials

- Complete in stainless steel, type 321

NOMINAL SIZE	MOVEMENT		OVERALL LENGTH SUPPLIED / INSTALLED*				MINIMUM ANCHOR LOAD AT TEST PRESSURE
	+ and -	TOTAL	BS4504 TABLE 6		BS10 TABLE E		
			L	*	L	*	
mm	mm	mm	mm	mm	mm	mm	kg
20	12.5 25	25 50	142 202	154.5 227	127 187	139.5 212	305
25	12.5 25	25 50	144 204	156.5 229	130 190	142.5 215	305
32	12.5 25	25 50	132 210	144.5 235	116 194	128.5 219	305
40	12.5 25	25 50	134 212	146.5 237	119 197	131.5 222	305
50	16 25	32 50	140 207	156 232	127 194	143 219	485
65	16 38	32 76	155 253	171 291	143 241	159 279	855
80	20 45	40 90	170 281	190 326	156 267	176 312	1200
100	25 50	50 100	202 319	227 369	191 308	216 358	1695
125	25 50	50 100	202 306	227 356	191 295	216 345	2610
150	25 50	50 100	214 300	239 350	209 295	234 345	3570

Notes

1. For unit sizes or operating conditions outside of the range specified above, please refer to Teddington Bellows.

* Installed length shown assumes total movement applied in compression.

UNIT TYPE

AS10

Small Bore Axial Unit with Unions

Small Bore Axial Unit with Unions

- Working pressure
10 bar gauge maximum
- Working temperature
200°C maximum
- Test pressure
15 bar gauge

End fittings

- Threaded unions
BS1740 - Part 1

Materials

- Bellows
Stainless steel, type 321
- Pipe ends
Carbon Steel
- Internal sleeves
Carbon Steel
- External shroud
Carbon Steel
- Threaded unions
Wrought Steel

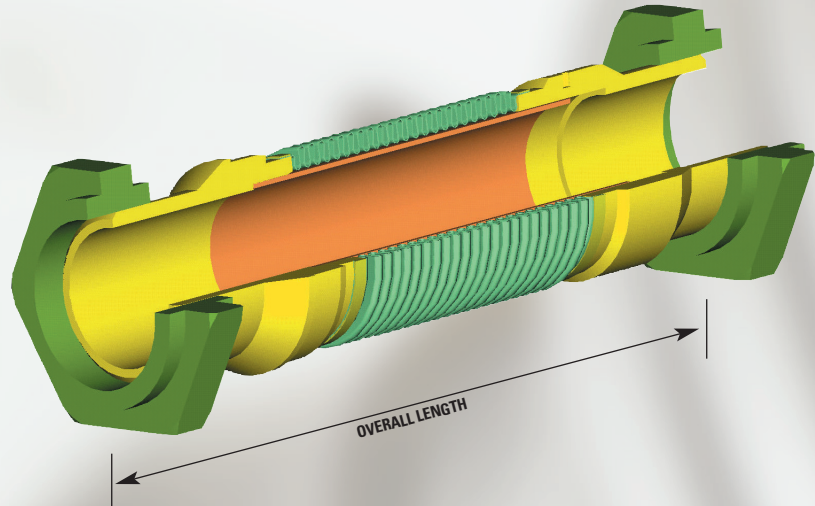

NOMINAL SIZE	MOVEMENT COMPRESSION ONLY	APPROXIMATE OVERALL LENGTH		MAX O/D EXTERNAL SHROUD	MINIMUM ANCHOR LOAD AT TEST PRESSURE
		SUPPLIED L	INSTALLED *		
mm	mm	mm	mm	mm	kg
15	30	300	300	27	75
20	30	330	330	38	85
25	30	360	360	44	125
32	30	390	390	54	180
40	30	405	405	74	240
50	30	420	420	76	250

Notes

1. The AS10 unit is pre-set at the factory and suitable for the compression movement shown from the installed length .
2. The unit is fitted with a pre-tensioning screw which must be removed after installation and prior to commissioning. Care should be taken to ensure that torque is NOT applied to the stainless steel bellows during installation.
3. For unit sizes or operating conditions outside of the range specified above, please refer to Teddington Bellows.

Teddington Restrained Bellows Expansion Joints

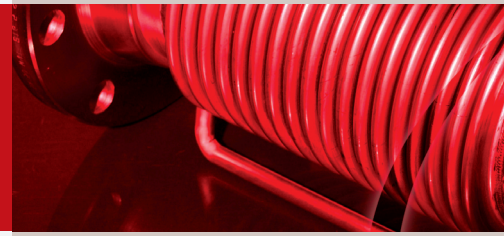

Restrained Bellows Expansion Joints as described in this brochure are restrained by hinged or spherical seated tied plates or bars along their longitudinal axis which prevent them from extending when subjected to pipeline pressure.

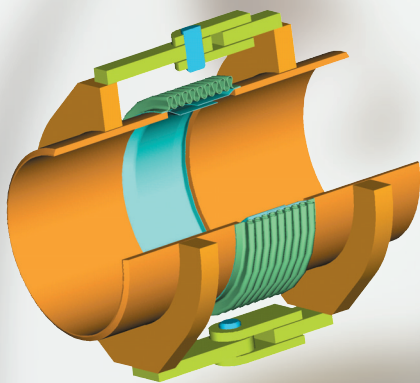

Unit Type

■ ANGULAR

(a) **Hinged** - a single bellows expansion joint which permits angular rotation in one plane only.

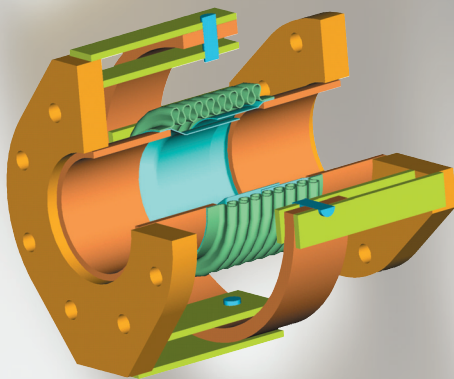

Unit Type

(b) **Gimbal** - a single bellows expansion joint which permits angular rotation in any plane.

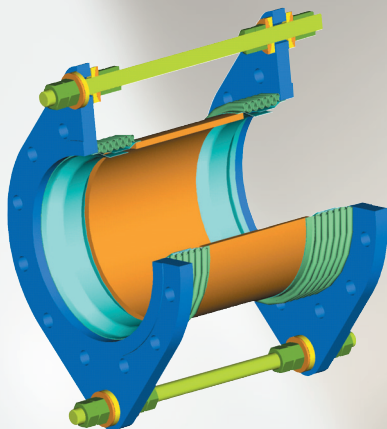

Unit Type

■ LATERAL (Transverse)

a double bellows expansion joint which permits relative displacement of its ends perpendicular to its longitudinal axis.

Whilst every effort has been made to ensure that the information contained in this brochure is correct, Teddington Bellows Ltd cannot be held responsible for any inaccuracies herein. We also reserve the right to change specifications without prior notice.

How to Specify

Any unit detailed in the following Data Sheets can be specified by quoting the following information in its Coded form.

UNIT TYPE	NOMINAL SIZE	TOTAL MOVEMENT	END FITTINGS	ACCESSORIES
<p>The type of unit available is indicated in the top right hand corner of each Data Sheet.</p> <p><i>Example:</i> A Hinged Double Unit suitable for a working pressure of 6 Bar would be specified as</p>	<p>The nominal size of units available are shown in the first column of each Data Sheet.</p> <p><i>Example:</i> Assuming pipeline being considered is 300mm nominal diameter, then this would be specified as</p>	<p>Having determined the movement to be accommodated by each unit, select the nearest appropriate movement from the range available.</p> <p><i>Example:</i> Assuming 300mm nominal diameter pipeline with a movement requirement of say 85mm, then nearest specified would be</p>	<p>The standard end fittings available with code are shown in the table below.</p> <p><i>Example:</i> Should you require unit flanged to BS 4504 - Table 6, then this would be specified as</p>	<p>The specified code for accessories is as follows:</p> <p>0 - no accessories required 1 - internal sleeve required 2 - external shroud required 3 - internal sleeve & external shroud required</p> <p><i>Example:</i> Should you require unit with internal sleeve, then this would be specified as</p>
HD6	300	100	006	1

The complete code would now be written as HD6/300/100/006/1

End Fitting Flanged			End Fitting Pipe Ends		
Unit Type	Flange	Code	Unit Type	Pipe Ends	Code
HS3.5: HD3.5	BS10 - Table A	001	HS3.5: HD3.5	BS1600 Part 2 Standard Wall	403
GS3.5: TD3.5	BS10 - Table D	002	GS3.5: TD 3.5		403
	PN6	006	HS6: HD 6	DIN 2458	405
HS6: HD6	BS10 - Table E	003	GS6: TD 6		405
GS6: TD6	ASA150	150	HS10: HD 10	DIN 2458	405
	PN6	006	GS10: TD 10		405
HS10: HD10	BS10 - Table F	004	HS16: HD 16	DIN 2458	405
GS10: TD10	ASA150	150	GS16: TD 16		405
	PN10	010	HS25: HD 25	DIN 2458	406
HS16: HD16	BS10 - Table H	005	GS25: TD 25		406
GS16: TD16	ASA300	300			
	PN16	016			
HS25: HD25	BS10 - Table H	005			
GS25: TD25	ASA300	300			
	PN25	025			

Hinged Single Unit with Flanges or Pipe Ends

UNIT TYPE

HS3.5

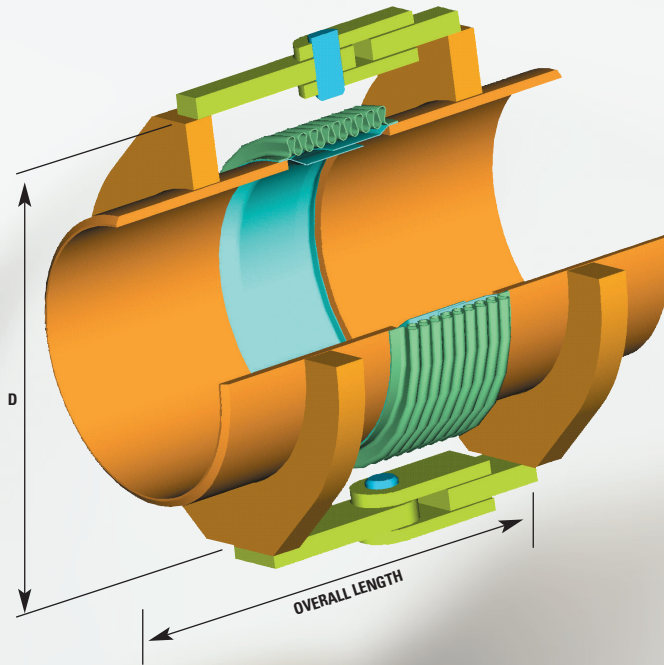

Hinged Single Unit with Flanges or Pipe Ends

- Working pressure
3.5 bar gauge maximum
- Working temperature
300°C maximum
- Test pressure
5.25 bar gauge

End fittings

- Flanges
(350 to 600 nom.) BS10 - Table D.(700 to 1200 nom.)
BS10-Table A (All sizes) BS4504 - Table 6.Pipe ends (All sizes)
BS1600 Part 2 STD Wall

Materials

- Bellows
Stainless steel, type 321
- Internal sleeves
Stainless steel, type 321
- Pipe Ends
Carbon Steel
- Flanges
Carbon Steel
- Hinge Restraint
Carbon Steel

NOMINAL SIZE	MOVEMENT		OVERALL LENGTH		PIPE SIZE		MAXIMUM 'D'		ANGULAR SPRING RATE
	+ and -	TOTAL	WELD ENDS	FLANGED	O/D	THK	WELD ENDS	FLANGED	
mm	deg	deg	mm	mm	mm	mm	mm	cm ²	NM/deg
350	8	16	610	380	355.6	5.0	585	610	50
400	8	16	610	380	406.4	5.6	635	685	60
450	8	16	635	405	457.2	6.3	685	710	110
500	7	14	635	405	508.0	6.3	735	785	150
600	7	14	760	430	609.6	8.0	840	890	250
700	5.5	11	760	430	711.2	8.8	965	1015	390
750	5	10	760	455	762.0	8.8	1015	1090	470
800	4.5	9	760	455	812.8	8.8	1065	1170	630
900	4	8	785	480	914.4	10.0	1170	1270	940
1000	4	8	810	510	1016.0	11.0	1195	1395	1300
1050	3.5	7	915	585	1065.0	11.0	1270	1475	1500
1100	3.5	7	940	585	1120.0	12.0	1320	1525	1750
1200	3.5	7	735	610	1220.0	13.0	1590	1650	2200

Notes

1. For unit sizes or operating conditions outside of the range specified above, please refer to Teddington Bellows.
2. For units above Nominal Size 12 inch (300 mm Nom.) flanged to BS10: 1962, the nominal size as shown in column 1 of the above table refers to the outside diameter of the line pipe. It follows that in accordance with BS10: 1962 a 16 inch nominal size (400mm Nom.) would have a flange size designation of 15 inches.

UNIT TYPE

HS6

Hinged Single Unit with Flanges or Pipe Ends

Hinged Single Unit with Flanges or Pipe Ends

- Working pressure
6 bar gauge maximum
- Working temperature
300°C maximum
- Test pressure
10 bar gauge

End fittings

- Flanges
BS10 - Table E, ASA 150,
BS4504 - Table 6
- Pipe ends
DIN 2458

Materials

- Bellows
Stainless steel, type 321
- Internal sleeves
Stainless steel, type 321
- Pipe Ends
Carbon Steel
- Flanges
Carbon Steel
- Hinge Restraint
Carbon Steel

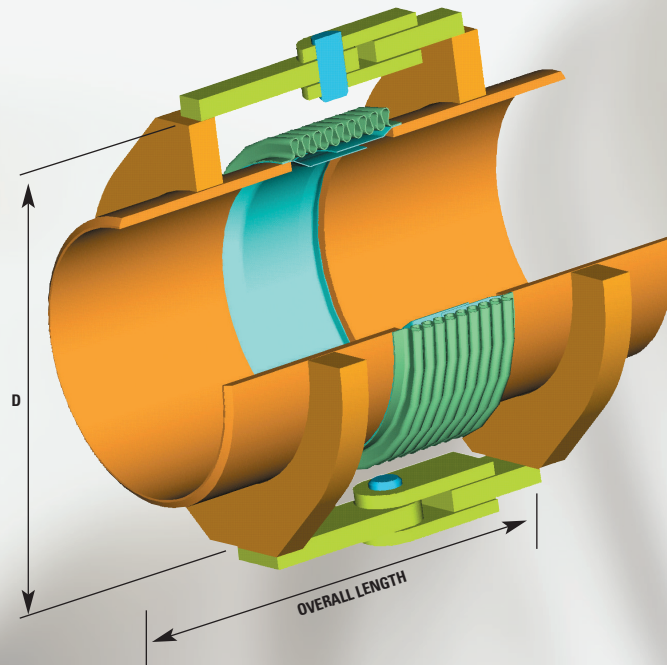

NOMINAL SIZE	MOVEMENT		OVERALL LENGTH		PIPE SIZE		MAXIMUM 'D'		ANGULAR SPRING RATE
	+ and -	TOTAL	WELD ENDS	FLANGED	O/D	THK	WELD ENDS	FLANGED	
mm	deg	deg	mm	mm	mm	mm	mm	cm ²	NM/deg
80	10	20	360	380	88.9	3.2	205	205	10
100	10	20	380	400	114.3	3.6	230	230	10
125	10	20	385	405	139.7	3.6	255	255	10
150	10	20	450	470	168.3	4.0	280	280	20
200	10	20	480	500	219.1	4.5	355	355	60
250	8	16	510	525	273.0	5.0	405	405	110
300	8	16	515	535	323.9	5.6	480	480	120
350	8	16	585	380	355.6	5.6	585	610	120
400	8	16	610	380	406.4	6.3	635	685	130
450	8	16	660	405	457.2	6.3	685	710	270
500	7	14	685	430	508.0	6.3	735	785	370
600	6	12	760	455	609.6	8.0	865	915	600
700	5.5	11	785	455	711.2	8.8	990	1040	1000
750	5	10	810	480	762.0	8.8	1065	1115	1200
800	4.5	9	840	510	812.8	8.8	1115	1195	1450

Notes

1. For unit sizes or operating conditions outside of the range specified above, please refer to Teddington Bellows.
2. For units above Nominal Size 12 inch (300 mm Nom.), flanged to BS10: 1962, the nominal size as shown in column 1 of the above table refers to the outside diameter of the line pipe. It follows that in accordance with BS10: 1962 a 16 inch nominal size (400mm Nom.) would have a flange size designation of 15 inches.

Hinged Single Unit with Flanges or Pipe Ends

UNIT TYPE

HS10

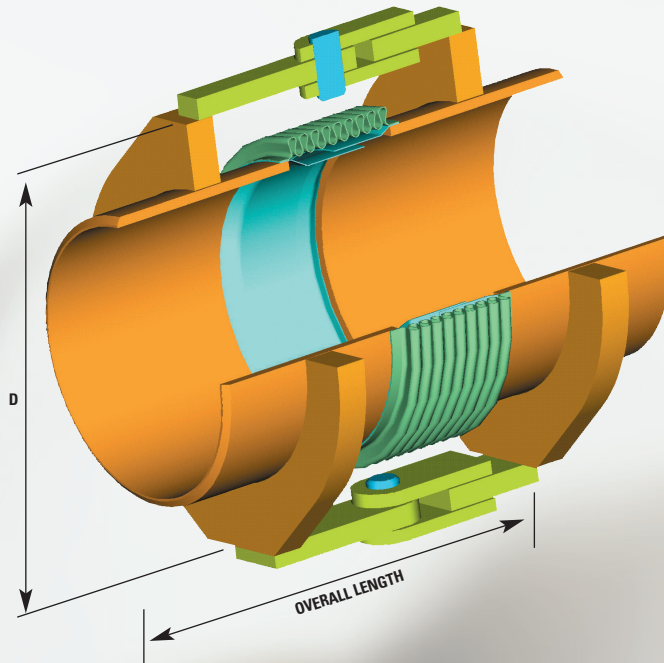

Hinged Single Unit with Flanges or Pipe Ends

- Working pressure
10 bar gauge maximum
- Working temperature
300°C maximum
- Test pressure
15 bar gauge

End fittings

- Flanges
BS10 - Table F, ASA 150,
BS4504 - Table 10
- Pipe ends
DIN 2458

Materials

- Bellows
Stainless steel, type 321
- Internal sleeves
Stainless steel, type 321
- Pipe Ends
Carbon Steel
- Flanges
Carbon Steel
- Hinge Restraint
Carbon Steel

NOMINAL SIZE	MOVEMENT		OVERALL LENGTH		PIPE SIZE		MAXIMUM 'D'		ANGULAR SPRING RATE
	+ and -	TOTAL	WELD ENDS	FLANGED	O/D	THK	WELD ENDS	FLANGED	
mm	deg	deg	mm	mm	mm	mm	mm	cm ²	NM/deg
80	10	20	360	380	88.9	3.2	205	205	10
100	10	20	380	400	114.3	3.6	230	255	10
125	10	20	385	405	139.7	3.6	255	280	10
150	10	20	450	470	168.3	4.0	280	330	20
200	8	16	480	500	219.1	4.5	355	380	60
250	7	14	510	525	273.0	5.0	405	455	11 a
300	8	16	515	535	323.9	5.6	480	535	170
350	8	16	660	405	355.6	5.6	585	660	120
400	8	16	710	430	406.4	6.3	635	735	220
450	8	16	735	430	457.2	6.3	710	810	390
500	7	14	785	455	508.0	6.3	760	890	500
600	6	12	785	480	609.6	8.0	890	1040	900
700	5.5	11	660	535	711.2	8.8	1015	1170	1400
750	5	10	685	560	762.0	8.8	1090	1245	1700
800	4.5	9	735	610	812.8	8.8	1145	1295	2500

Notes

1. For unit sizes or operating conditions outside of the range specified above, please refer to Teddington Bellows.
2. For units above Nominal Size 12 inch (300 mm Nom.) flanged to BS10: 1962, the nominal size as shown in column 1 of the above table refers to the outside diameter of the line pipe. It follows that in accordance with BS10: 1962 a 16 inch nominal size (400mm Nom.) would have a flange size designation of 15 inches.

UNIT TYPE

HS16

Hinged Single Unit with Flanges or Pipe Ends

Hinged Single Unit with Flanges or Pipe Ends

- Working pressure
16 bar gauge maximum
- Working temperature
300°C maximum
- Test pressure
25 bar gauge

End fittings

- Flanges
BS10 - Table H, ASA 300,
BS4504 - Table 16
- Pipe ends
DIN 2458

Materials

- Bellows
Stainless steel, type 321
- Internal sleeves
Stainless steel, type 321
- Pipe Ends
Carbon Steel
- Flanges
Carbon Steel
- Hinge Restraint
Carbon Steel

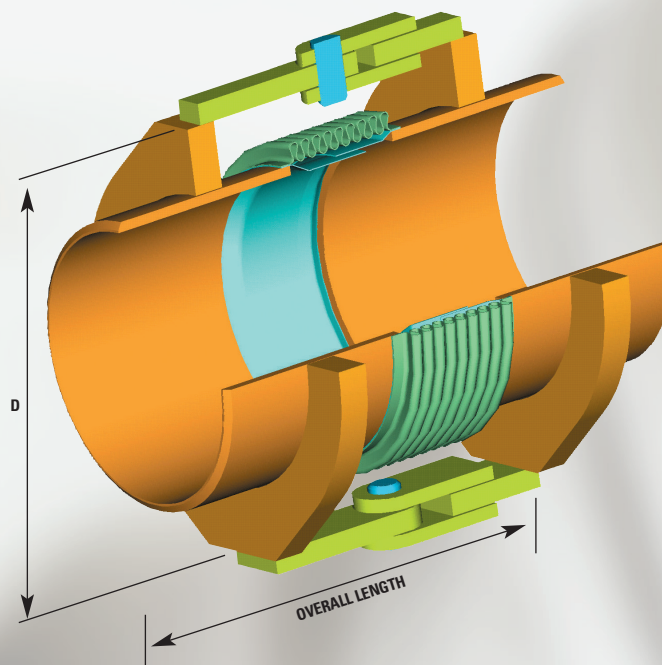

NOMINAL SIZE	MOVEMENT		OVERALL LENGTH		PIPE SIZE		MAXIMUM 'D'		ANGULAR SPRING RATE
	+ and -	TOTAL	WELD ENDS	FLANGED	O/D	THK	WELD ENDS	FLANGED	
mm	deg	deg	mm	mm	mm	mm	mm	cm ²	NM/deg
80	10	20	360	380	88.9	3.2	205	205	10
100	10	20	380	400	114.3	3.6	230	255	10
125	10	20	385	405	139.7	3.6	255	280	10
150	8	16	450	470	168.3	4.0	280	330	20
200	7	14	480	500	219.1	4.5	355	380	60
250	6	12	510	525	273.0	5.0	455	455	110
300	8	16	660	685	323.9	5.6	535	535	220
350	8	16	785	480	355.6	5.6	585	685	200
400	8	16	810	480	406.4	6.3	635	760	280
450	8	16	840	510	457.2	6.3	735	840	400
500	7	14	865	510	508.0	6.3	810	915	550
600	6	12	915	560	609.6	8.0	965	1065	900
700	5.5	11	940	610	711.2	8.8	1090	1220	1450
750	5	10	940	1015	762.0	8.8	1145	1295	1750
800	4.5	9	1040	1245	812.8	8.8	1220	1345	2100

Notes

1. For unit sizes or operating conditions outside of the range specified above, please refer to Teddington Bellows.
2. For units above Nominal Size 12 inch (300 mm Nom.), flanged to BS10: 1962, the nominal size as shown in column 1 of the above table refers to the outside diameter of the line pipe. It follows that in accordance with BS10: 1962 a 16 inch nominal size (400mm Nom.) would have a flange size designation of 15 inches.

Hinged Single Unit with Flanges or Pipe Ends

UNIT TYPE

HS25

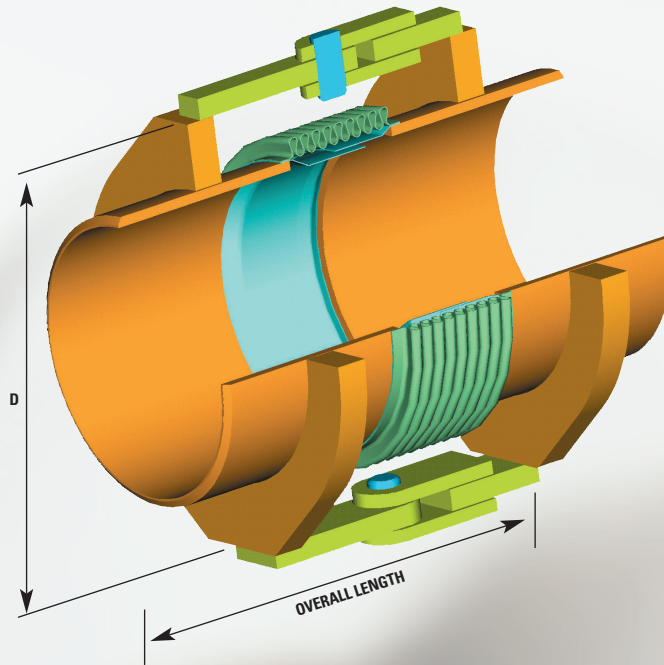

Hinged Single Unit with Flanges or Pipe Ends

- Working pressure
25 bar gauge maximum
- Working temperature
300°C maximum
- Test pressure
37.5 bar gauge

End fittings

- Flanges
BS10 - Table H, ASA 300,
BS4504 - Table 25
- Pipe ends
DIN 2458

Materials

- Bellows
Stainless steel, type 321
- Internal sleeves
Stainless steel, type 321
- Pipe Ends
Carbon Steel
- Flanges
Carbon Steel
- Hinge Restraint
Carbon Steel

NOMINAL SIZE	MOVEMENT		OVERALL LENGTH		PIPE SIZE		MAXIMUM 'D'		ANGULAR SPRING RATE
	+ and -	TOTAL	WELD ENDS	FLANGED	O/D	THK	WELD ENDS	FLANGED	
mm	deg	deg	mm	mm	mm	mm	mm	cm ²	NM/deg
80	10	20	360	380	88.9	3.2	205	205	10
100	10	20	380	400	114.3	3.6	230	255	10
125	10	20	425	445	139.7	4.0	255	280	20
150	9	18	450	470	168.3	4.5	330	330	30
200	7	14	585	585	219.1	6.2	405	405	80
250	6	12	660	660	273.0	6.3	480	480	140
300	5	10	785	455	323.9	7.1	585	635	350
350	7	14	810	455	355.6	8.0	660	735	300
400	6.5	13	865	510	406.4	8.8	710	810	440
450	6	12	685	560	457.2	10.0	810	890	600
500	5.5	11	710	585	508.0	10.0	1170	965	850
600	5	10	890	965	609.6	To be specified by customer	1065	1145	1400
700	4	8	1090	1270	711.2		1245	1320	2450
750	3.5	7	1195	1370	762.0		1295	1370	3000
800	3.5	7	1320	1525	812.8		1370	1445	3600

Notes

1. For unit sizes or operating conditions outside of the range specified above, please refer to Teddington Bellows.
2. For units above Nominal Size 12 inch (300 mm Nom.) flanged to BS10: 1962, the nominal size as shown in column 1 of the above table refers to the outside diameter of the line pipe. It follows that in accordance with BS10: 1962 a 16 inch nominal size (400mm Nom.) would have a flange size designation of 15 inches.

UNIT TYPE

HD3.5

Hinged Double Unit with Flanges or Pipe Ends

Hinged Double Unit with Flanges or Pipe Ends

- Working pressure
3.5 bar gauge maximum
- Working temperature
300°C maximum
- Test pressure
5.25 bar gauge
- Basic Movement
+ and - 25mm lateral

End fittings

- Flanges
(350 to 600 nom.) BS10 - Table D. (700 to 1200 nom.) BS10-Table A. (All sizes) BS4504 - Table 6
- Pipe ends
(All sizes) BS1600 Part 2 STD Wall

Materials

- Bellows
Stainless steel, type 321
- Internal sleeves
Stainless steel, type 321
- Pipe Ends
Carbon Steel
- Flanges
Carbon Steel
- Hinge Restraint
Carbon Steel

Notes

1. For unit sizes or operating conditions outside of the range specified above, please refer to Teddington Bellows.
2. For unit above Nominal Size 12 inch (300 mm Nom.), flanged to BS10: 1962, the nominal size as shown in column 1 of the above table refers to the outside diameter of the line pipe. It follows that in accordance with BS10: 1962 a 16 inch nominal size (400mm Nom) would have a flange size designation of 15 inches.
3. By increasing distance between bellows centres 'z' the lateral movement potential is increased. Add multiples of 'z' to the unit overall length for every additional + and - 25mm required over the basic + and - 25mm movement given in the specification.
4. The 'new' lateral spring rate after increasing 'z' becomes

$$\frac{(\text{Original measure } Z)^2 \times \text{original lateral rate}}{(\text{New measure } Z)^2}$$

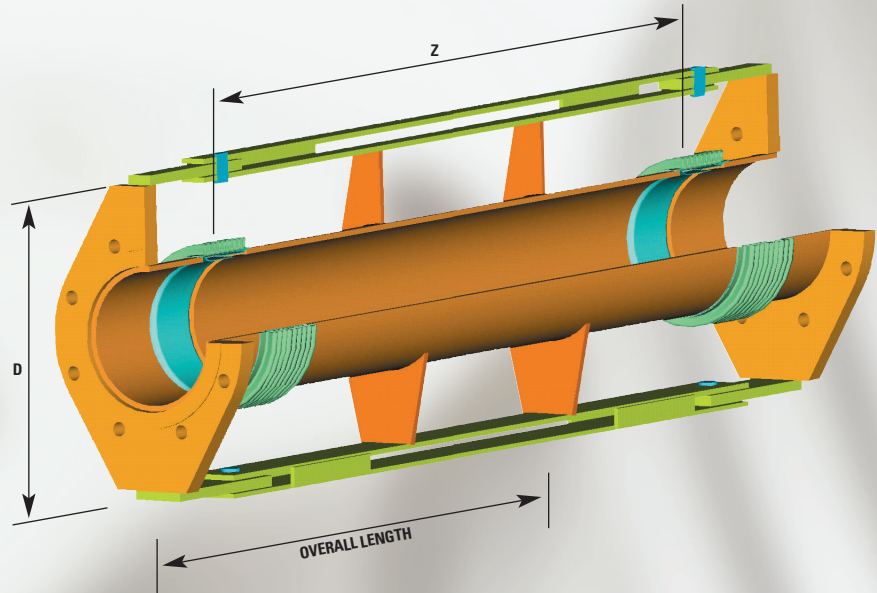

NOMINAL SIZE	OVERALL LENGTH		PIPE SIZE		MAXIMUM 'D'		ADDITIONAL MEASURE Z TO GIVE + AND - 25mm ADDITIONAL MOVEMENT	+ AND - ANG° PER BELLOWS	SPRING RATE	
	WELD ENDS	FLANGED	O/D	THK	WELD ENDS	FLANGED			LATERAL	ANGULAR
mm	mm	mm	mm	mm	mm	mm	mm	deg	N/mm	NM/deg
350	840	610	355.6	5.0	585	610	240	8	85	50
400	865	610	406.4	5.6	635	685	240	8	125	60
450	890	660	457.2	6.3	685	710	255	8	200	110
500	890	660	508.0	6.3	735	785	255	7	265	150
600	965	685	609.6	8.0	840	890	255	7	440	250
700	1015	710	711.2	8.8	965	1015	270	5.5	615	390
750	1015	735	762.0	8.8	1015	1090	290	5	625	470
800	1065	785	812.8	8.8	1065	1170	330	4.5	660	630
900	1065	840	914.4	10.0	1170	1270	360	4	825	940
1000	1145	840	1016.0	11.0	1195	1395	360	4	1150	1300
1050	1245	890	1065.0	11.0	1270	1475	420	3.5	1000	1500
1100	1245	890	1120.0	12.0	1320	1525	420	3.5	1150	1750
1200	1015	915	1220.0	13.0	1590	1650	420	3.5	1450	2200

Hinged Double Unit with Flanges or Pipe Ends

UNIT TYPE

HD6

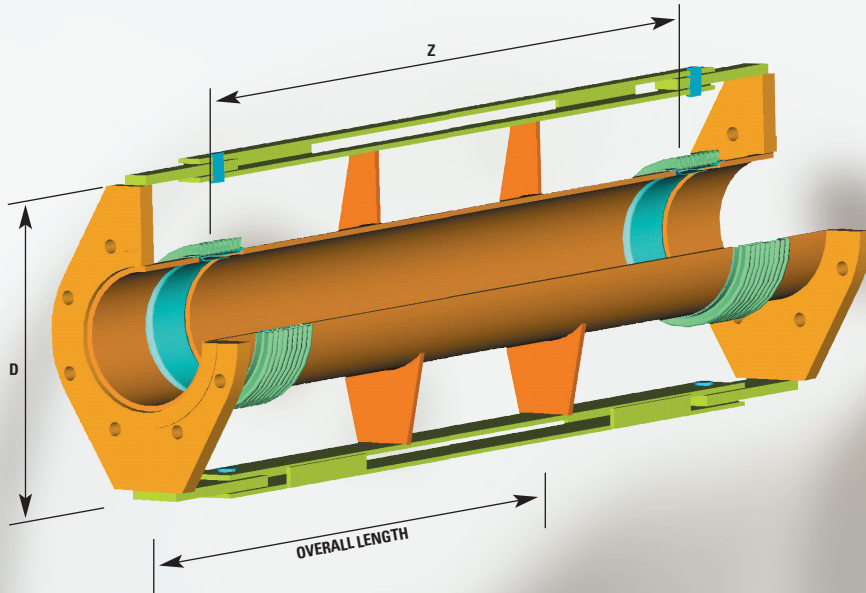

Hinged Double Unit with Flanges or Pipe Ends

- Working pressure
6 bar gauge maximum
- Working temperature
300°C maximum
- Test pressure
10 bar gauge
- Basic Movement
+ and - 25mm lateral

End fittings

- Flanges
BS10 - Table E, ASA 150,
BS4504 - Table 6
- Pipe ends
DIN 2458

Materials

- Bellows
Stainless steel, type 321
- Internal sleeves
Stainless steel, type 321
- Pipe Ends
Carbon Steel
- Flanges
Carbon Steel
- Hinge Restraint
Carbon Steel

NOMINAL SIZE	OVERALL LENGTH		PIPE SIZE		MAXIMUM 'D'		ADDITIONAL MEASURE Z TO GIVE + AND - 25mm ADDITIONAL MOVEMENT	+ AND - ANG° PER BELLOWS	SPRING RATE	
	WELD ENDS	FLANGED	O/D	THK	WELD ENDS	FLANGED			LATERAL	ANGULAR
mm	mm	mm	mm	mm	mm	mm	mm	deg	N/mm	NM/deg
80	550	570	88.9	3.2	205	205	150	10	15	10
100	585	605	114.3	3.6	230	230	150	10	30	10
125	595	615	139.7	3.6	255	255	150	10	65	10
150	660	680	168.3	4.0	280	280	150	10	110	20
200	700	715	219.1	4.5	355	355	150	10	320	60
250	725	740	273.0	5.0	405	405	200	8	340	110
300	755	775	323.9	5.6	480	480	240	8	165	120
350	840	610	355.6	5.6	585	610	240	8	205	120
400	865	610	406.4	6.3	635	685	240	8	295	130
450	915	635	457.2	6.3	685	710	240	8	530	270
500	915	660	508.0	6.3	735	785	240	7	710	370
600	965	685	609.6	8.0	865	915	240	6	1150	600
700	1015	711	711.2	8.8	990	1040	265	5.5	1500	1000
750	1090	760	762.0	8.8	1065	1115	290	5	1750	1200
800	1170	810	812.8	8.8	1115	1195	330	4.5	1400	1450

Notes

1. For unit sizes or operating conditions outside of the range specified above, please refer to Teddington Bellows.
2. For unit above Nominal Size 12 inch (300 mm Nom.), flanged to BS10: 1962, the nominal size as shown in column 1 of the above table refers to the outside diameter of the line pipe. It follows that in accordance with BS10: 1962 a 16 inch nominal size (400mm Nom) would have a flange size designation of 15 inches.
3. By increasing distance between bellows centres 'z' the lateral movement potential is increased. Add multiples of 'z' to the unit overall length for every additional + and - 25mm required over the basic + and - 25mm movement given in the specification.
4. The 'new' lateral spring rate after increasing 'z' becomes

$$\frac{(\text{Original measure } Z)^2 \times \text{original lateral rate}}{(\text{New measure } Z)^2}$$

UNIT TYPE

HD10

Hinged Double Unit with Flanges or Pipe Ends

Hinged Double Unit with Flanges or Pipe Ends

- Working pressure
10 bar gauge maximum
- Working temperature
300°C maximum
- Test pressure
15 bar gauge
- Basic Movement
+ and - 25mm lateral

End fittings

- Flanges
BS10 - Table F, ASA 150,
BS4504 - Table 10
- Pipe ends
DIN 2458

Materials

- Bellows
Stainless steel, type 321
- Internal sleeves
Stainless steel, type 321
- Pipe Ends
Carbon Steel
- Flanges
Carbon Steel
- Hinge Restraint
Carbon Steel

Notes

1. For unit sizes or operating conditions outside of the range specified above, please refer to Teddington Bellows.
2. For unit above Nominal Size 12 inch (300 mm Nom.), flanged to BS10: 1962, the nominal size as shown in column 1 of the above table refers to the outside diameter of the line pipe. It follows that in accordance with BS10: 1962 a 16 inch nominal size (400mm Nom) would have a flange size designation of 15 inches.
3. By increasing distance between bellows centres 'z' the lateral movement potential is increased. Add multiples of 'z' to the unit overall length for every additional + and - 25mm required over the basic + and - 25mm movement given in the specification.
4. The 'new' lateral spring rate after increasing 'z' becomes

$$\frac{(\text{Original measure } Z)^2 \times \text{original lateral rate}}{(\text{New measure } Z)^2}$$

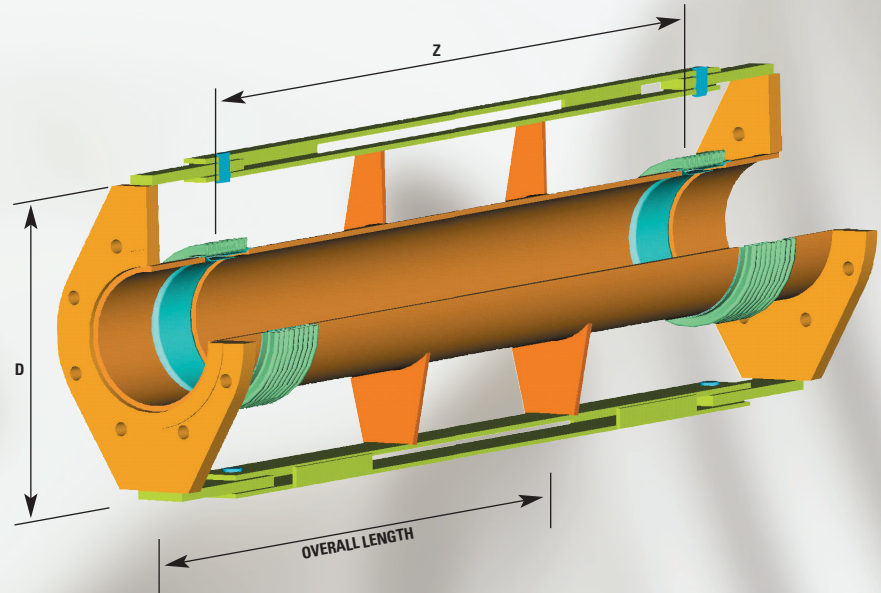

NOMINAL SIZE	OVERALL LENGTH		PIPE SIZE		MAXIMUM 'D'		ADDITIONAL MEASURE Z TO GIVE + AND - 25mm ADDITIONAL MOVEMENT	+ AND - ANG° PER BELLOWS	SPRING RATE	
	WELD ENDS	FLANGED	O/D	THK	WELD ENDS	FLANGED			LATERAL	ANGULAR
mm	mm	mm	mm	mm	mm	mm	mm	deg	N/mm	NM/deg
80	550	570	88.9	3.2	205	205	150	10	15	10
100	585	605	114.3	3.6	230	255	150	10	30	10
125	595	615	139.7	3.6	255	280	150	10	65	10
150	660	680	168.3	4.0	280	330	150	10	110	20
200	700	715	219.1	4.5	355	380	200	8	180	60
250	725	740	273.0	5.0	405	455	215	7	300	110
300	755	775	323.9	5.6	480	535	240	8	245	170
350	915	635	355.6	5.6	585	660	240	8	260	120
400	965	660	406.4	6.3	635	735	240	8	375	220
450	965	685	457.2	6.3	710	810	240	8	805	390
500	1015	685	508.0	6.3	760	890	240	7	1090	500
600	1040	710	609.6	8.0	890	1040	240	6	1800	900
700	915	710	711.2	8.8	1015	1170	265	5.5	2300	1400
750	965	840	762.0	8.8	1090	1245	290	5	2300	1700
800	1040	840	812.8	8.8	1145	1295	330	4.5	2150	2500

Hinged Double Unit with Flanges or Pipe Ends

UNIT TYPE

HD16

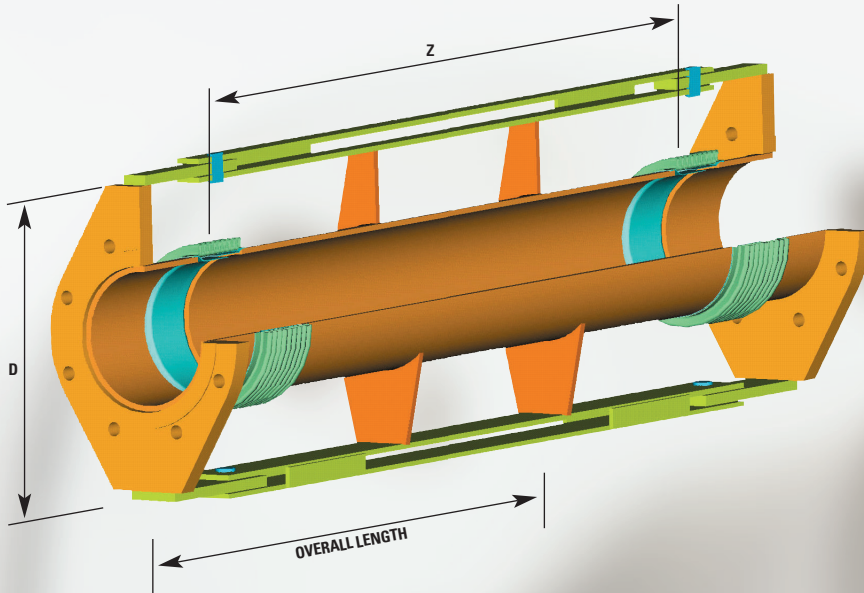

Hinged Double Unit with Flanges or Pipe Ends

- Working pressure
16 bar gauge maximum
- Working temperature
300°C maximum
- Test pressure
25 bar gauge
- Basic Movement
+ and - 25mm lateral

End fittings

- Flanges
BS10 - Table H, ASA 300,
BS4504 - Table 16
- Pipe ends
DIN 2458

Materials

- Bellows
Stainless steel, type 321
- Internal sleeves
Stainless steel, type 321
- Pipe Ends
Carbon Steel
- Flanges
Carbon Steel
- Hinge Restraint
Carbon Steel

NOMINAL SIZE	OVERALL LENGTH		PIPE SIZE		MAXIMUM 'D'		ADDITIONAL MEASURE Z TO GIVE + AND - 25mm ADDITIONAL MOVEMENT	+ AND - ANG° PER BELLOWS	SPRING RATE	
	WELD ENDS	FLANGED	O/D	THK	WELD ENDS	FLANGED			LATERAL	ANGULAR
mm	mm	mm	mm	mm	mm	mm	mm	deg	N/mm	NM/deg
80	550	560	88.9	3.2	205	205	150	10	15	10
100	585	605	114.3	3.6	230	255	150	10	30	10
125	595	615	139.7	3.6	255	280	150	10	65	10
150	660	680	168.3	4.0	280	330	205	8	65	20
200	700	715	219.1	4.5	355	380	215	7	160	60
250	750	770	273.0	5.0	455	455	240	6	240	110
300	915	940	323.9	5.6	535	535	240	8	325	220
350	1090	810	355.6	5.6	585	685	305	8	265	200
400	1145	810	406.4	6.3	635	760	305	8	380	280
450	1145	810	457.2	6.3	735	840	305	8	570	400
500	1170	810	508.0	6.3	810	915	305	7	755	550
600	1170	865	609.6	8.0	965	1065	305	6	1250	900
700	1145	915	711.2	8.8	1090	1220	305	5.5	1950	1450
750	1170	1345	762.0	8.8	1145	1295	325	5	2050	1750
800	1370	1575	812.8	8.8	1220	1345	330	4.5	2400	2100

Notes

1. For unit sizes or operating conditions outside of the range specified above, please refer to Teddington Bellows.
2. For unit above Nominal Size 12 inch (300 mm Nom.), flanged to BS10: 1962, the nominal size as shown in column 1 of the above table refers to the outside diameter of the line pipe. It follows that in accordance with BS10: 1962 a 16 inch nominal size (400mm Nom) would have a flange size designation of 15 inches.
3. By increasing distance between bellows centres 'z' the lateral movement potential is increased. Add multiples of 'z' to the unit overall length for every additional + and - 25mm required over the basic + and - 25mm movement given in the specification.
4. The 'new' lateral spring rate after increasing 'z' becomes

$$\frac{(\text{Original measure } Z)^2 \times \text{original lateral rate}}{(\text{New measure } Z)^2}$$

UNIT TYPE

HD25

Hinged Double Unit with Flanges or Pipe Ends

Hinged Double Unit with Flanges or Pipe Ends

- Working pressure
25 bar gauge maximum
- Working temperature
300°C maximum
- Test pressure
37.5 bar gauge
- Basic Movement
+ and - 25mm lateral

End fittings

- Flanges
BS10 - Table H, ASA 300,
BS4504 - Table 25
- Pipe ends
DIN 2458

Materials

- Bellows
Stainless steel, type 321
- Internal sleeves
Stainless steel, type 321
- Pipe Ends
Carbon Steel
- Flanges
Carbon Steel
- Hinge Restraint
Carbon Steel

Notes

1. For unit sizes or operating conditions outside of the range specified above, please refer to Teddington Bellows.
2. For unit above Nominal Size 12 inch (300 mm Nom.), flanged to BS10: 1962, the nominal size as shown in column 1 of the above table refers to the outside diameter of the line pipe. It follows that in accordance with BS10: 1962 a 16 inch nominal size (400mm Nom) would have a flange size designation of 15 inches.
3. By increasing distance between bellows centres 'z' the lateral movement potential is increased. Add multiples of 'z' to the unit overall length for every additional + and - 25mm required over the basic + and - 25mm movement given in the specification.
4. The 'new' lateral spring rate after increasing 'z' becomes

$$\frac{\text{(Original measure Z)}^2 \times \text{original lateral rate}}{\text{(New measure Z)}^2}$$

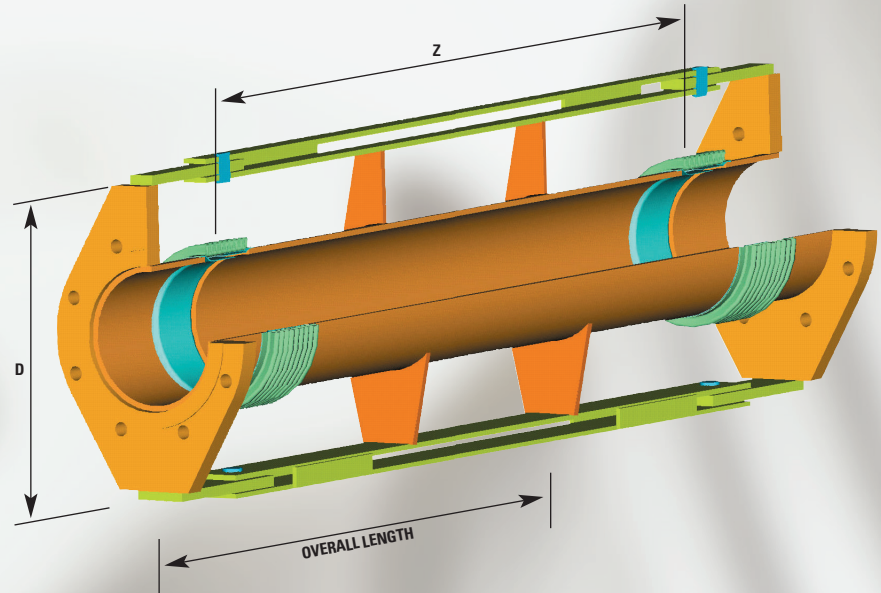

NOMINAL SIZE	OVERALL LENGTH		PIPE SIZE		MAXIMUM 'D'		ADDITIONAL MEASURE Z TO GIVE + AND - 25mm ADDITIONAL MOVEMENT	+ AND - ANG° PER BELLOWS	SPRING RATE	
	WELD ENDS	FLANGED	O/D	THK	WELD ENDS	FLANGED			LATERAL	ANGULAR
mm	mm	mm	mm	mm	mm	mm	mm	deg	N/mm	NM/deg
80	550	570	88.9	3.2	205	205	150	10	30	10
100	595	615	114.3	3.6	230	255	150	10	55	10
125	635	655	139.7	4.0	255	280	150	10	100	20
150	660	680	168.3	4.5	330	330	175	9	125	30
200	800	820	219.1	6.2	405	405	215	7	255	80
250	900	920	273.0	6.3	480	480	240	6	375	140
300	1065	735	323.9	7.1	585	635	290	5	615	350
350	1090	735	355.6	8.0	660	735	265	7	615	300
400	1145	760	406.4	8.8	710	810	265	6.5	890	440
450	890	840	457.2	10.0	810	890	265	6	1250	600
500	890	760	508.0	10.0	1170	965	265	5.5	1650	850
600	1040	760	609.6	To be specified by customer	1065	1145	290	5	2300	1400
700	1220	865	711.2		1245	1320	365	4	2250	2450
750	1295	945	762.0		1295	1370	415	3.5	2100	3000
800	1320	1650	812.8		1370	1445	415	3.5	2250	3600

Tied Double Unit with Flanges or Pipe Ends

UNIT TYPE

TD3.5

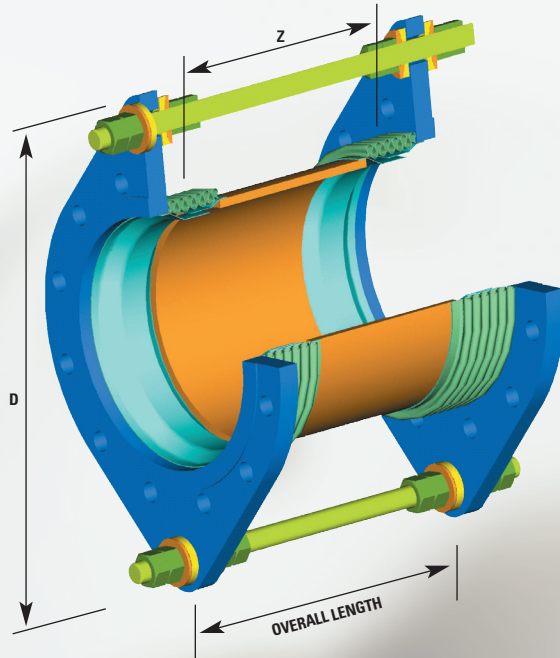

Hinged Double Unit with Flanges or Pipe Ends

- Working pressure
3.5 bar gauge maximum
- Working temperature
300°C maximum
- Test pressure
5.25 bar gauge
- Basic Movement
+ and - 25mm lateral

End fittings

- Flanges
(350 to 600 nom.) BS10 - Table D. (700 to 1200 nom.) BS10-Table A. (All sizes) BS4504 - Table 6
- Pipe Ends
(All sizes) BS1600 Part 2 STD Wall

Materials

- Bellows
Stainless steel, type 321
- Internal sleeves
Stainless steel, type 321
- Pipe Ends
Carbon Steel
- Flanges
Carbon Steel
- Hinge Restraint
Carbon Steel

Notes

1. For unit sizes or operating conditions outside of the range specified above, please refer to Teddington Bellows.
2. For unit above Nominal Size 12 inch (300 mm Nom.), flanged to BS10: 1962, the nominal size as shown in column 1 of the above table refers to the outside diameter of the line pipe. It follows that in accordance with BS10: 1962 a 16 inch nominal size (400mm Nom) would have a flange size designation of 15 inches.
3. By increasing distance between bellows centres 'z' the lateral movement potential is increased. Add multiples of 'z' to the unit overall length for every additional + and - 25mm required over the basic + and - 25mm movement given in the specification.
4. The 'new' lateral spring rate after increasing 'z' becomes

$$\frac{(\text{Original measure } \mathbf{Z})^2 \times \text{original lateral rate}}{(\text{New measure } \mathbf{Z})^2}$$

NOMINAL SIZE	OVERALL LENGTH		PIPE SIZE		MAXIMUM 'D'		ADDITIONAL MEASURE Z TO GIVE + AND - 25mm ADDITIONAL MOVEMENT	+ AND - ANG° PER BELLOWS	SPRING RATE	
	WELD ENDS	FLANGED	O/D	THK	WELD ENDS	FLANGED			LATERAL	ANGULAR
mm	mm	mm	mm	mm	mm	mm	mm	deg	N/mm	NM/deg
350	760	610	355.6	5.0	635	635	240	8	85	50
400	760	610	406.4	5.6	685	735	240	8	125	60
450	840	660	457.2	6.3	760	785	255	8	200	110
500	840	660	508.0	6.3	840	865	255	7	265	150
600	865	685	609.6	8.0	940	1015	255	7	440	250
700	890	710	711.2	8.8	1065	1145	270	5.5	615	390
750	915	760	762.0	8.8	1115	1220	290	5	625	470
800	965	815	812.8	8.8	1170	1320	330	4.5	660	630
900	990	840	914.4	10.0	1245	1420	360	4	825	940
1000	1065	915	1016.0	11.0	1395	1575	360	4	1150	1300
1050	1140	990	1065.0	11.0	1475	1650	420	3.5	1000	1500
1100	1140	1005	1120.0	12.0	1525	1725	420	3.5	1150	1750
1200	1195	1015	1220.0	13.0	1625	1855	420	3.5	1450	2200

UNIT TYPE

TD6

Tied Double Unit with Flanges or Pipe Ends

Tied Double Unit with Flanges or Pipe Ends

- Working pressure
6 bar gauge maximum
- Working temperature
300°C maximum
- Test pressure
10 bar gauge
- Basic movement
+ and - 25 mm lateral

End fitting

- Flanges
BS10 - Table E, ASA 150,
BS4504 - Table 6
- Pipe ends
DIN 2458

Materials

- Bellows
Stainless steel, type 321
- Internal sleeves
Stainless steel, type 321
- Pipe Ends
Carbon Steel
- Flanges
Carbon Steel
- Tied Restraint
Carbon Steel

Notes

1. For unit sizes or operating conditions outside of the range specified above, please refer to Teddington Bellows.
2. For unit above Nominal Size 12 inch (300 mm Nom.), flanged to BS10: 1962, the nominal size as shown in column 1 of the above table refers to the outside diameter of the line pipe. It follows that in accordance with BS10: 1962 a 16 inch nominal size (400mm Nom) would have a flange size designation of 15 inches.
3. By increasing distance between bellows centres 'z' the lateral movement potential is increased. Add multiples of 'z' to the unit overall length for every additional + and - 25mm required over the basic + and - 25mm movement given in the specification.
4. The 'new' lateral spring rate after increasing 'z' becomes

$$\frac{(\text{Original measure } Z)^2 \times \text{original lateral rate}}{(\text{New measure } Z)^2}$$

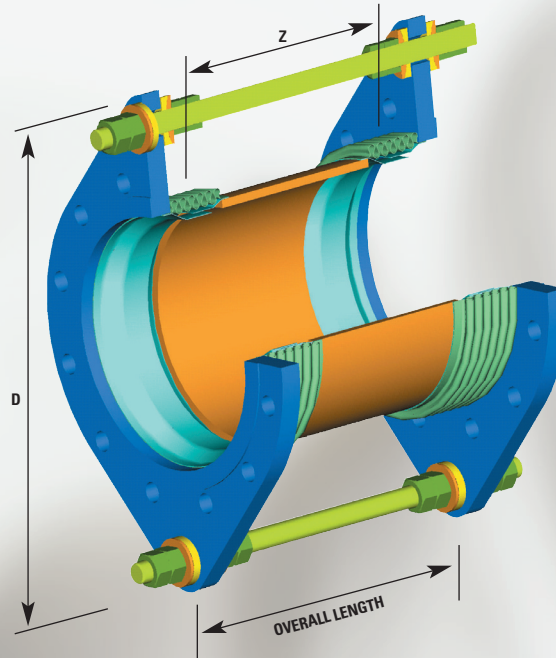

NOMINAL SIZE	OVERALL LENGTH		PIPE SIZE		MAXIMUM 'D'		ADDITIONAL MEASURE Z TO GIVE + AND - 25mm ADDITIONAL MOVEMENT	+ AND - ANG° PER BELLOWS	SPRING RATE	
	WELD ENDS	FLANGED	O/D	THK	WELD ENDS	FLANGED			LATERAL	ANGULAR
mm	mm	mm	mm	mm	mm	mm	mm	deg	N/mm	NM/deg
80	550	570	88.9	3.2	205	255	150	10	15	10
100	585	605	114.3	3.6	255	305	150	10	30	10
125	595	615	139.7	3.6	280	355	150	10	65	10
150	660	680	168.3	4.0	330	380	150	10	110	20
200	700	715	219.1	4.5	405	485	150	10	320	60
250	725	740	273.0	5.0	480	560	200	8	340	110
300	755	775	323.9	5.6	560	660	240	8	165	120
350	785	810	355.6	5.6	660	710	240	8	205	120
400	810	840	406.4	6.3	711	790	240	8	295	130
450	840	885	457.2	6.3	787	865	240	8	530	270
500	865	915	508.0	6.3	865	965	240	7	710	370
600	890	960	609.6	8.0	940	1115	240	6	1150	600
700	940	1010	711.2	8.8	1065	1220	265	5.5	1500	1000
750	990	1065	762.0	8.8	1145	1320	290	5	1750	1200
800	1040	1125	812.8	8.8	1195	1370	330	4.5	1400	1450

Tied Double Unit with Flanges or Pipe Ends

UNIT TYPE

TD10

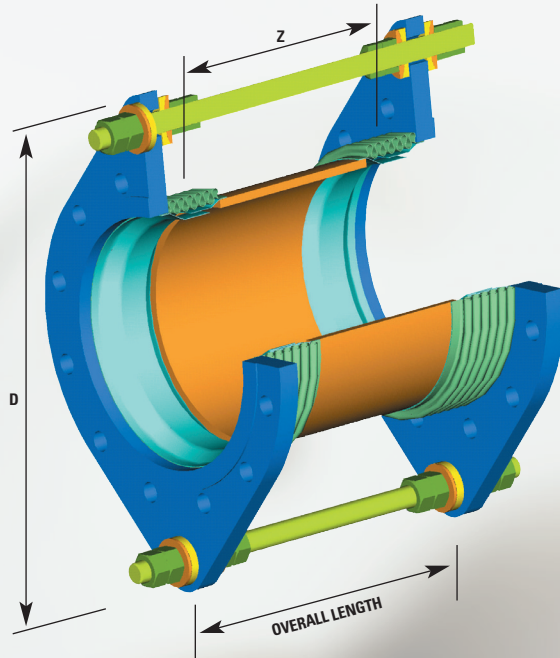

NOMINAL SIZE	OVERALL LENGTH		PIPE SIZE		MAXIMUM 'D'		ADDITIONAL MEASURE Z TO GIVE + AND - 25mm ADDITIONAL MOVEMENT	+ AND - ANG° PER BELLOWS	SPRING RATE	
	WELD ENDS	FLANGED	O/D	THK	WELD ENDS	FLANGED			LATERAL	ANGULAR
mm	mm	mm	mm	mm	mm	mm	mm	deg	N/mm	NM/deg
80	550	570	88.9	3.2	230	280	150	10	15	10
100	585	605	114.3	3.6	255	305	150	10	30	10
125	595	615	139.7	3.6	280	355	150	10	65	10
150	660	680	168.3	4.0	330	380	150	10	110	20
200	700	715	219.1	4.5	405	480	200	8	180	60
250	725	740	273.0	5.0	480	585	215	7	300	110
300	755	775	323.9	5.6	560	660	240	8	245	170
350	840	660	355.6	5.6	660	785	240	8	260	120
400	865	685	406.4	6.3	735	865	240	8	375	220
450	915	685	457.2	6.3	815	965	240	8	805	390
500	915	685	508.0	6.3	865	1065	240	7	1090	500
600	965	710	609.6	8.0	990	1220	240	6	1800	900
700	1020	785	711.2	8.8	1115	1370	265	5.5	2300	1400
750	1095	815	762.0	8.8	1195	1475	290	5	2300	1700
800	1090	865	812.8	8.8	1270	1550	330	4.5	2150	2500

Tied Double Unit with Flanges or Pipe Ends

- Working pressure
10 bar gauge maximum
- Working temperature
300°C maximum
- Test pressure
15 bar gauge
- Basic movement
+ and - 25 mm lateral

End fitting

- Flanges
BS10 - Table F, ASA 150,
BS4504 - Table 10
- Pipe ends
DIN 2458

Materials

- Bellows
Stainless steel, type 321
- Internal sleeves
Stainless steel, type 321
- Pipe Ends
Carbon Steel
- Flanges
Carbon Steel
- Tied Restraint
Carbon Steel

Notes

1. For unit sizes or operating conditions outside of the range specified above, please refer to Teddington Bellows.
2. For unit above Nominal Size 12 inch (300 mm Nom.), flanged to BS10: 1962, the nominal size as shown in column 1 of the above table refers to the outside diameter of the line pipe. It follows that in accordance with BS10: 1962 a 16 inch nominal size (400mm Nom) would have a flange size designation of 15 inches.
3. By increasing distance between bellows centres 'z' the lateral movement potential is increased. Add multiples of 'z' to the unit overall length for every additional + and - 25mm required over the basic + and - 25mm movement given in the specification.
4. The 'new' lateral spring rate after increasing 'z' becomes

$$\frac{(\text{Original measure } Z)^2 \times \text{original lateral rate}}{(\text{New measure } Z)^2}$$

UNIT TYPE

TD16

Tied Double Unit with Flanges or Pipe Ends

Tied Double Unit with Flanges or Pipe Ends

- Working pressure
16 bar gauge maximum
- Working temperature
300°C maximum
- Test pressure
25 bar gauge
- Basic movement
+ and - 25 mm lateral

End fitting

- Flanges
BS10 - Table H, ASA 300,
BS4504 - Table 16
- Pipe ends
DIN 2458

Materials

- Bellows
Stainless steel, type 321
- Internal sleeves
Stainless steel, type 321
- Pipe Ends
Carbon Steel
- Flanges
Carbon Steel
- Tied Restraint
Carbon Steel

Notes

1. For unit sizes or operating conditions outside of the range specified above, please refer to Teddington Bellows.
2. For unit above Nominal Size 12 inch (300 mm Nom.), flanged to BS10: 1962, the nominal size as shown in column 1 of the above table refers to the outside diameter of the line pipe. It follows that in accordance with BS10: 1962 a 16 inch nominal size (400mm Nom) would have a flange size designation of 15 inches.
3. By increasing distance between bellows centres 'z' the lateral movement potential is increased. Add multiples of 'z' to the unit overall length for every additional + and - 25mm required over the basic + and - 25mm movement given in the specification.
4. The 'new' lateral spring rate after increasing 'z' becomes

$$\frac{(\text{Original measure } Z)^2 \times \text{original lateral rate}}{(\text{New measure } Z)^2}$$

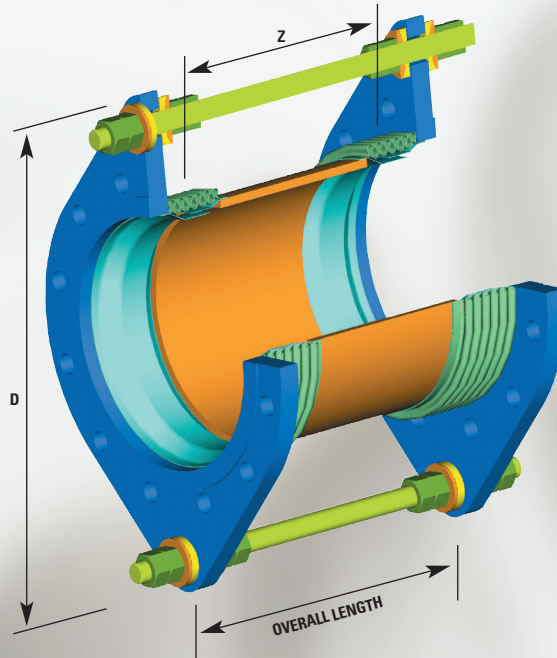

NOMINAL SIZE	OVERALL LENGTH		PIPE SIZE		MAXIMUM 'D'		ADDITIONAL MEASURE Z TO GIVE + AND - 25mm ADDITIONAL MOVEMENT	+ AND - ANG° PER BELLOWS	SPRING RATE	
	WELD ENDS	FLANGED	O/D	THK	WELD ENDS	FLANGED			LATERAL	ANGULAR
mm	mm	mm	mm	mm	mm	mm	mm	deg	N/mm	NM/deg
80	550	570	88.9	3.2	230	330	150	10	15	10
100	585	605	114.3	3.6	280	380	150	10	30	10
125	595	615	139.7	3.6	330	430	150	10	65	10
150	660	680	168.3	4.0	355	480	205	8	65	20
200	700	715	219.1	4.5	430	560	215	7	160	60
250	750	770	273.0	5.0	510	685	240	6	240	110
300	915	940	323.9	5.6	585	710	240	8	325	220
350	1015	810	355.6	5.6	685	840	305	8	265	200
400	1040	810	406.4	6.3	735	940	305	8	380	280
450	1090	810	457.2	6.3	835	1015	305	8	570	400
500	1145	810	508.0	6.3	910	1120	305	7	755	550
600	1145	810	609.6	8.0	1040	1295	305	6	1250	900
700	1145	1420	711.2	8.8	1195	1475	305	5.5	1950	1450
750	1270	1420	762.0	8.8	1320	1320	325	5	2050	1750
800	1320	1525	812.8	8.8	1370	1370	330	4.5	2400	2100

Tied Double Unit with Flanges or Pipe Ends

UNIT TYPE

TD25

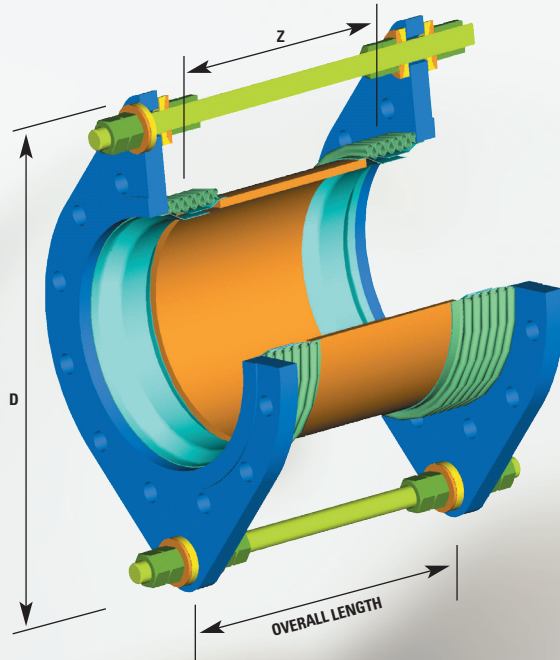

NOMINAL SIZE	OVERALL LENGTH		PIPE SIZE		MAXIMUM 'D'		ADDITIONAL MEASURE Z TO GIVE + AND - 25mm ADDITIONAL MOVEMENT	+ AND - ANG° PER BELLOWS	SPRING RATE	
	WELD ENDS	FLANGED	O/D	THK	WELD ENDS	FLANGED			LATERAL	ANGULAR
mm	mm	mm	mm	mm	mm	mm	mm	deg	N/mm	NM/deg
80	550	570	88.9	3.2	255	330	150	10	30	10
100	595	615	114.3	3.6	305	405	150	10	55	10
125	635	655	139.7	4.0	330	430	150	10	100	20
150	660	680	168.3	4.5	380	480	175	9	125	30
200	800	820	219.1	6.2	455	635	215	7	255	80
250	900	920	273.0	6.3	535	685	240	6	375	140
300	1065	735	323.9	7.1	610	710	290	5	615	350
350	1015	735	355.6	8.0	735	890	265	7	615	300
400	1065	760	406.4	8.8	810	990	265	6.5	890	440
450	1090	760	457.2	10.0	865	1090	265	6	1250	600
500	1090	760	508.0	10.0	965	1165	265	5.5	1650	850
600	1090	1320	609.6	To be specified by customer	1115	1115	290	5	2300	1400
700	1220	1500	711.2		1295	1295	365	4	2250	2450
750	1270	1575	762.0		1370	1370	415	3.5	2100	3000
800	1295	1625	812.8		1500	1500	415	3.5	2250	3600

Tied Double Unit with Flanges or Pipe Ends

- Working pressure
25 bar gauge maximum
- Working temperature
300°C maximum
- Test pressure
37.5 bar gauge
- Basic movement
+ and - 25 mm lateral

End fitting

- Flanges
BS10 - Table H, ASA 300, BS4504 - Table 25
- Pipe ends
DIN 2458

Materials

- Bellows
Stainless steel, type 321
- Internal sleeves
Stainless steel, type 321
- Pipe Ends
Carbon Steel
- Flanges
Carbon Steel
- Tied Restraint
Carbon Steel

Notes

1. For unit sizes or operating conditions outside of the range specified above, please refer to Teddington Bellows.
2. For unit above Nominal Size 12 inch (300 mm Nom.), flanged to BS10: 1962, the nominal size as shown in column 1 of the above table refers to the outside diameter of the line pipe. It follows that in accordance with BS10: 1962 a 16 inch nominal size (400mm Nom) would have a flange size designation of 15 inches.
3. By increasing distance between bellows centres 'z' the lateral movement potential is increased. Add multiples of 'z' to the unit overall length for every additional + and - 25mm required over the basic + and - 25mm movement given in the specification.
4. The 'new' lateral spring rate after increasing 'z' becomes

$$\frac{(\text{Original measure } Z)^2 \times \text{original lateral rate}}{(\text{New measure } Z)^2}$$

UNIT TYPE

GS3.5

Gimbal Single Unit with Flanges or Pipe Ends

Gimbal Single Unit with Flanges or Pipe Ends

- Working pressure
3.5 bar gauge maximum
- Working temperature
300°C maximum
- Test pressure
5.25 bar gauge

End fittings

- Flanges
(350 to 600 nom.) BS10 - Table D. (700 to 1200 nom.)
BS10 - TableA. (All sizes)
BS4504 - Table 6
- Pipe ends
(All sizes)
BS1600 Part 2 STD Wall

Materials

- Bellows
Stainless steel, type 321
- Internal sleeves
Carbon Steel
- Pipe Ends
Carbon Steel
- Flanges
Carbon Steel
- Gimbal Restraint
Carbon Steel

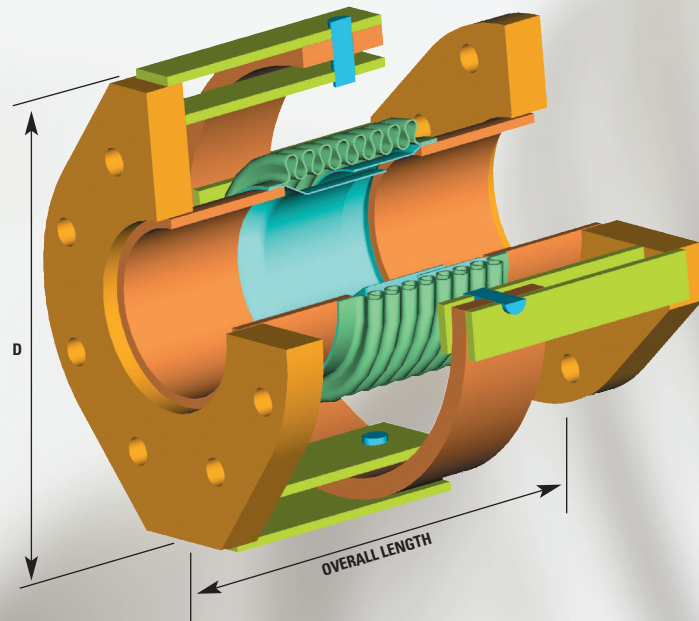

NOMINAL SIZE	MOVEMENT		OVERALL LENGTH		PIPE SIZE		MAXIMUM 'D'		AXIAL SPRING RATE
	+ and -	TOTAL	WELD ENDS	FLANGED	O/D	THK	WELD ENDS	FLANGED	
mm	deg	deg	mm	mm	mm	mm	mm	cm ²	NM/deg
350	8	16	610	380	355.6	5.0	610	660	50
400	8	16	610	380	406.4	5.6	685	735	60
450	8	16	635	405	457.2	6.3	760	785	110
500	7	14	635	405	508.0	6.3	810	865	150
600	7	14	760	430	609.6	8.0	965	990	250
700	5.5	11	760	430	711.2	8.8	1095	1115	390
750	5	10	760	455	762.0	8.8	1170	1220	470
800	4.5	9	760	455	812.8	8.8	1245	1295	630
900	4	8	785	480	914.4	10.0	1370	1445	940
1000	4	8	810	510	1016.0	11.0	1445	1445	1300
1050	3.5	7	915	585	1065.0	11.0	1500	1525	1500
1100	3.5	7	940	585	1120.0	12.0	1550	1625	1750
1200	3.5	7	735	610	1220.0	13.0	1650	1780	2200

Notes

1. For unit sizes or operating conditions outside of the range specified above, please refer to Teddington Bellows.
2. The nominal size as shown in column 1 of the above table refers to the outside diameter of the line pipe. It follows that in accordance with BS10: 1962 a 16 inch nominal size (400mm Nom) would have a flange size designation of 15 inches.

Gimbal Single Unit with Flanges or Pipe Ends

UNIT TYPE
GS6

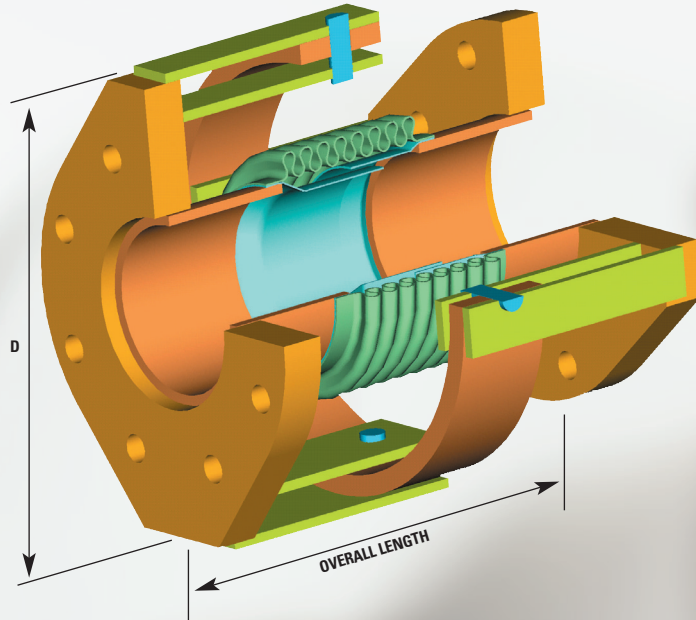

Gimbal Single Unit with Flanges or Pipe Ends

- Working pressure
6 bar gauge maximum
- Working temperature
300°C maximum
- Test pressure
10 bar gauge

End fittings

- Flanges
BS10 - Table E, ASA 150,
BS4504 - Table 6
- Pipe ends
DIN 2458

Materials

- Bellows
Stainless steel, type 321
- Internal sleeves
Carbon Steel
- Pipe Ends
Carbon Steel
- Flanges
Carbon Steel
- Gimbal Restraint
Carbon Steel

NOMINAL SIZE	MOVEMENT		OVERALL LENGTH		PIPE SIZE		MAXIMUM 'D'		ANGULAR SPRING RATE
	+ and -	TOTAL	WELD ENDS	FLANGED	O/D	THK	WELD ENDS	FLANGED	
mm	deg	deg	mm	mm	mm	mm	mm	cm ²	NM/deg
80	10	20	380	380	88.9	3.2	140	190	10
100	10	20	380	400	114.3	3.6	150	230	10
125	10	20	385	405	139.7	3.6	175	255	10
150	10	20	450	470	168.3	4.0	205	280	20
200	10	20	480	500	219.1	4.5	265	340	60
250	8	16	510	525	273.0	5.0	380	405	110
300	8	16	515	535	323.9	5.6	510	510	120
350	8	16	585	380	355.6	5.6	610	660	120
400	8	16	610	380	406.4	6.3	685	735	130
450	8	16	635	405	457.2	6.3	760	785	270
500	7	14	685	405	508.0	6.3	810	865	370
600	6	12	760	405	609.6	8.0	965	990	600
700	5.5	11	785	430	711.0	8.8	1090	1115	1000
750	5	10	710	430	762.0	8.8	1170	1220	1200
800	4.5	9	685	455	812.8	8.8	1245	1300	1450

Notes

1. For unit sizes or operating conditions outside of the range specified above, please refer to Teddington Bellows.
2. For units above Nominal Size 12 inch (300mm Nom.), flanged to BS10: 1962, the nominal size as shown in column 1 of the above table refers to the outside diameter of the line pipe. It follows that in accordance with BS10: 1962 a 16 inch nominal size (400mm Nom.) would have a flange size designation of 15 inches.

UNIT TYPE

GS10

Gimbal Single Unit with Flanges or Pipe Ends

Gimbal Single Unit with Flanges or Pipe Ends

- Working pressure
10 bar gauge maximum
- Working temperature
300°C maximum
- Test pressure
15 bar gauge

End fittings

- Flanges
BS10 - Table F, ASA 150,
BS4504 - Table 10
- Pipe ends
DIN 2458

Materials

- Bellows
Stainless steel, type 321
- Internal sleeves
Carbon Steel
- Pipe Ends
Carbon Steel
- Flanges
Carbon Steel
- Gimbal Restraint
Carbon Steel

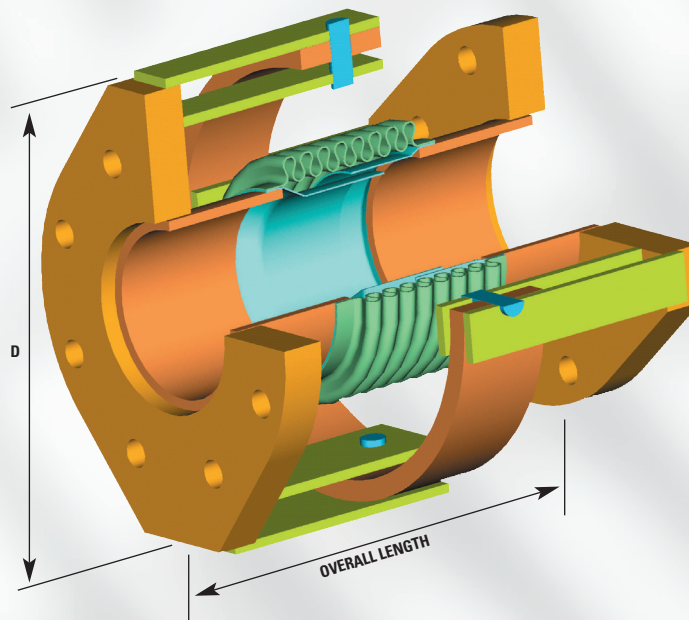

NOMINAL SIZE	MOVEMENT		OVERALL LENGTH		PIPE SIZE		MAXIMUM 'D'		ANGULAR SPRING RATE
	+ and -	TOTAL	WELD ENDS	FLANGED	O/D	THK	WELD ENDS	FLANGED	
mm	deg	deg	mm	mm	mm	mm	mm	cm ²	NM/deg
80	10	20	360	380	88.9	3.2	190	215	10
100	10	20	380	400	114.3	3.6	215	255	10
125	10	20	385	405	139.7	3.6	240	280	10
150	10	20	450	470	168.3	4.0	290	315	20
200	8	16	480	500	219.1	4.5	365	380	60
250	7	14	510	525	273.0	5.0	445	445	110
300	8	16	515	535	323.9	5.6	530	530	170
350	8	16	660	405	355.6	5.6	610	660	120
400	8	16	710	430	406.4	6.3	685	735	220
450	8	16	735	430	457.2	6.3	760	810	390
500	7	14	785	455	508.0	6.3	840	875	500
600	6	12	785	455	609.6	8.0	990	1040	900
700	5.5	11	660	535	711.2	8.8	1090	1170	1400
750	5	10	685	550	762.0	8.8	1195	1245	1700
800	4.5	9	735	610	812.8	8.8	1220	1295	2500

Notes

1. For unit sizes or operating conditions outside of the range specified above, please refer to Teddington Bellows.
2. The nominal size as shown in column 1 of the above table refers to the outside diameter of the line pipe. It follows that in accordance with BS10: 1962 a 16 inch nominal size (400mm Nom) would have a flange size designation of 15 inches.

Gimbal Single Unit with Flanges or Pipe Ends

UNIT TYPE

GS16

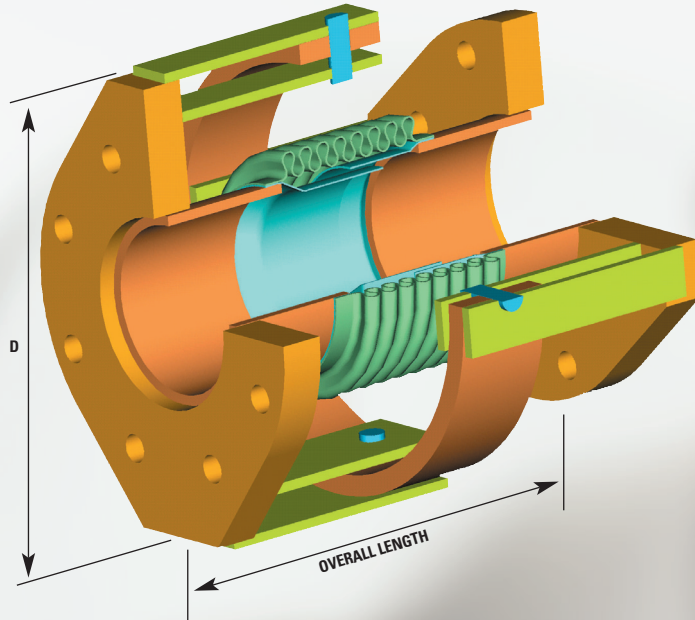

Gimbal Single Unit with Flanges or Pipe Ends

- Working pressure
16 bar gauge maximum
- Working temperature
300°C maximum
- Test pressure
25 bar gauge

End fittings

- Flanges
BS10 - Table H, ASA 300,
BS4504 - Table 16
- Pipe ends
DIN 2458

Materials

- Bellows
Stainless steel, type 321
- Internal sleeves
Stainless steel, type 321
- Pipe Ends
Carbon Steel
- Flanges
Carbon Steel
- Gimbal Restraint
Carbon Steel

NOMINAL SIZE	MOVEMENT		OVERALL LENGTH		PIPE SIZE		MAXIMUM 'D'		ANGULAR SPRING RATE
	+ and -	TOTAL	WELD ENDS	FLANGED	O/D	THK	WELD ENDS	FLANGED	
mm	deg	deg	mm	mm	mm	mm	mm	cm ²	NM/deg
80	10	20	360	380	88.9	3.2	190	215	10
100	10	20	380	400	114.3	3.6	215	255	10
125	10	20	385	405	139.7	3.6	240	280	10
150	8	16	450	470	168.3	4.0	290	315	20
200	7	14	480	500	219.1	4.5	370	380	60
250	6	12	510	525	273.0	5.0	445	445	110
300	8	16	660	685	323.9	5.6	535	535	220
350	8	16	785	480	355.6	5.6	610	660	200
400	8	16	810	480	406.4	6.3	685	735	280
450	8	16	840	510	457.2	6.3	760	810	400
500	7	14	865	510	508.0	6.3	840	890	550
600	6	12	915	560	609.6	8.0	990	1040	900
700	5.5	11	840	610	711.2	8.8	1090	1245	1450
750	5	10	940	660	762.0	8.8	1190	1320	1750
800	4.5	9	1040	685	812.8	8.8	1245	1395	2100

Notes

1. For unit sizes or operating conditions outside of the range specified above, please refer to Teddington Bellows.
2. For units above Nominal Size 12 inch (300 mm Nom.) flanged to BS10: 1962, the nominal size as shown in column 1 of the above table refers to the outside diameter of the line pipe. It follows that in accordance with BS10: 1962 a 16 inch nominal size (400mm Nom.) would have a flange size designation of 15 inches.

UNIT TYPE

GS25

Gimbal Single Unit with Flanges or Pipe Ends

Gimbal Single Unit with Flanges or Pipe Ends

- Working pressure
25 bar gauge maximum
- Working temperature
300°C maximum
- Test pressure
37.5 bar gauge

End fittings

- Flanges
BS10 - Table H, ASA 300,
BS4504 - Table 25
- Pipe ends
DIN 2458

Materials

- Bellows
Stainless steel, type 321
- Internal sleeves
Stainless steel, type 321
- Pipe Ends
Carbon Steel
- Flanges
Carbon Steel
- Gimbal Restraint
Carbon Steel

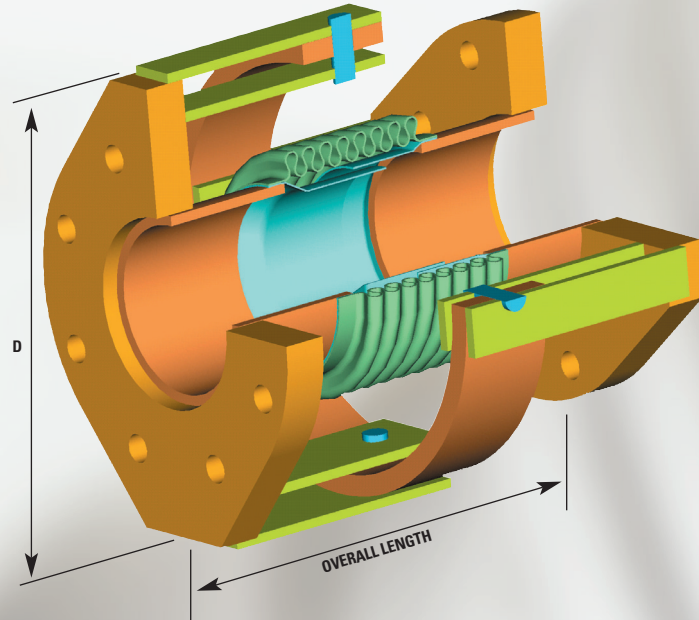

NOMINAL SIZE	MOVEMENT		OVERALL LENGTH		PIPE SIZE		MAXIMUM 'D'		ANGULAR SPRING RATE
	+ and -	TOTAL	WELD ENDS	FLANGED	O/D	THK	WELD ENDS	FLANGED	
mm	deg	deg	mm	mm	mm	mm	mm	cm ²	NM/deg
80	10	20	360	380	88.9	3.2	205	215	10
100	10	20	380	400	114.3	3.6	230	255	10
125	10	20	425	445	139.7	4.0	255	280	2b
150	9	18	450	470	168.3	4.5	305	315	30
200	7	14	585	585	219.1	6.2	380	380	80
250	6	12	660	660	273.0	6.3	455	455	140
300	5	10	535	455	323.9	7.1	545	545	350
350	7	14	810	455	355.6	8.0	635	660	300
400	6.5	13	865	455	406.4	8.8	760	785	440
450	6	12	685	480	457.2	10.0	810	865	600
500	5.5	11	710	560	508.0	10.0	890	940	850
600	5	10	890	610	609.6	To be specified by customer	990	1065	1400
700	4	8	1090	735	711.2		1145	1270	2450
750	3.5	7	1195	760	762.0		1220	1345	3000
800	3.5	7	1320	810	812.8		1295	1445	3600

Notes

1. For unit sizes or operating conditions outside of the range specified above, please refer to Teddington Bellows.
2. The nominal size as shown in column 1 of the above table refers to the outside diameter of the line pipe. It follows that in accordance with BS10: 1962 a 16 inch nominal size (400mm Nom) would have a flange size designation of 15 inches.

Flexible Hoses - FBH Series EPDM Rubber Fancoil Hose



Design Conditions		Materials of Construction		Identification
Max. Working Pressure	16.0 Bar	Hose	EPDM (KTW approved)	Nom Bore,
Temperature Rating	-20.0 / +110.0°C	Outer Braid	304 Stainless Steel	Country of origin,
Max. Test Pressure	31.0 Bar	Ferrules	Stainless Steel	Date of manufacture,
Guarantee	10 Years	Fittings	Nickel Plated Brass	Type No.

Specification:

Teddington type FBH fancoil hose manufactured from EPDM rubber with stainless steel outer braid and nickel plated brass end fittings. End fittings attached by swaged stainless steel ferrules. Refer to next page for end fitting options.

All type FBH EPDM hoses supplied with 10 year guarantee and £2.0m product liability insurance.

Technical Data						
Nominal Bore	Hose Length mm	Hose I/dia mm	Min Length 90° Bend mm	Min Length 180° Bend mm	Pressure Rating 100°C Bar	Pressure Rating 20°C Bar
13 (1/2")	300	13.0	258	352	10.0	25.0
	450					
20 (3/4")	600	19.0	344	470	10.0	25.0
	300					
	450					
25 (1")	300	25.0	423	580	10.0	25.0
	450					
	600					

Typical Applications:

FBH EPDM hoses are designed to allow maximum flexibility for misalignment of pipe work and vibration isolation from fancoil units and are suitable for heating and chilled water systems. The EPDM lining is ageing resistant in heating systems. Due to the flexibility of this range of hoses, special care must be taken during installation - always refer to installation instructions.

Accessories:

FBH hoses can be provided with vapour sealed Armaflex class 'O' insulation when required on chilled water applications.

Flexible Hoses - FBH Series EPDM Rubber Fancoil Hose

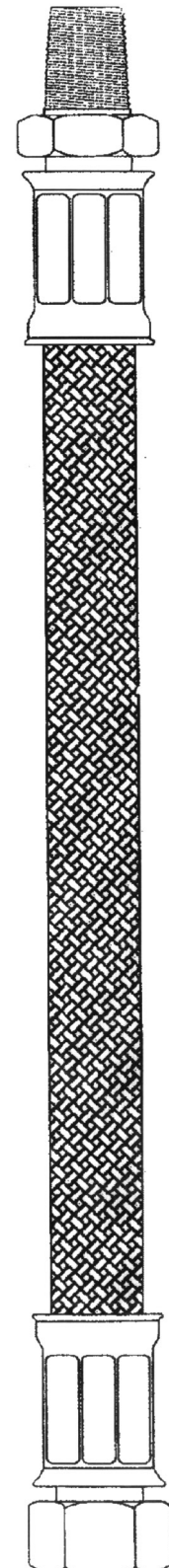

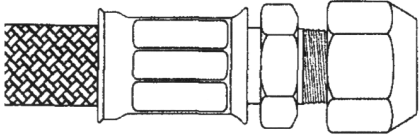
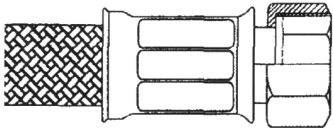
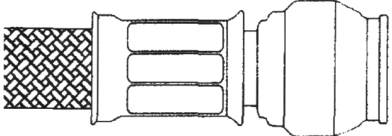
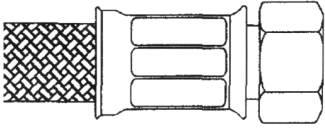
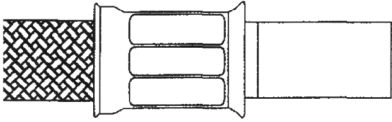
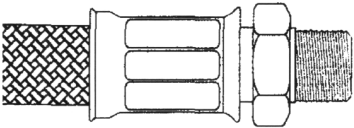
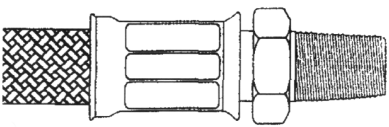
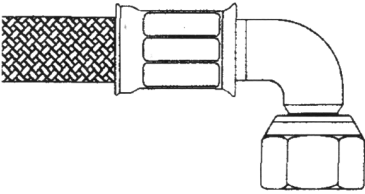

Flexible Hose End Fitting Options (HVAC)

End Fitting Option	Description	Nominal Bore
	CF Compression Fitting c/w Brass Nut and Olive	13, 20, 25 1/2", 3/4", 1"
	CF Swivel Female Nut c/w Cone Seat	13, 20, 25 1/2", 3/4", 1"
	PF Nickel Plated Brass 'PUSHFIT' c/w John Guest, Tectite OR other fittings	13 1/2"
	SF Swivel Female Nut c/w Flat Face Seat	13, 20, 25 1/2", 3/4", 1
	SP 25mm Long Brass Stub pipe end To suit copper fittings	13, 20, 25 1/2", 3/4", 1
	PM Fixed Male c/w Parallel Thread	13, 20, 25 1/2", 3/4", 1
	TM Fixed Male c/w BSP Taper Male	13, 20, 25 1/2", 3/4", 1
	EF 90° Elbow with Swivel Female Nut c/w Flat Face Seat	13, 20, 25 1/2", 3/4", 1

Flexible Hoses - FSH Series

Metallic Braided Flexible Hose



Design Conditions		Materials of Construction		Identification
Max. Working Pressure	To suit	Hose	304/321/316 Stainless Steel	As required
Temperature Rating	specific client	Outer Braid	304 Stainless Steel	according to
Max. Test Pressure	applications	Ferrules	Stainless Steel	P.E.D. 97/23/EC
		Fittings	Carbon or Stainless Steel	

Specification:

Teddington type FSH metallic flexible hose to suit client's specific pressure, temperature, movements or vibration applications. End fittings to suit client specific requirements. Refer to next page for end fitting examples.

Technical Data						
Nominal Bore	Hose Length mm	Hose Dimms I/dia mm	Hose Dimms O/Dia mm	Min Bend Radius mm	Pressure Rating 20°C Bar	No. of Outer Braids
6 (1/4") through to 250 (10")	Unlimited	Size Dependant Refer to size sheets	Size Dependant Refer to size sheets	Size Dependant Refer to size sheets	Size Dependant Refer to size sheets	Size and Pressure Dependant

Typical Applications:

FSH metallic flexible hoses are designed to allow maximum flexibility for misalignment of pipe work, compensate for pipe line thermal expansion and vibration isolation. Due to the flexibility of this range of hoses, special care must be taken during installation - always refer to installation instructions.

Accessories:

FSH hoses can be provided with vapour sealed Armaflex class 'O' insulation when required on chilled water applications.

Flexible Hoses - FSH Series

Metallic Braided Flexible Hose



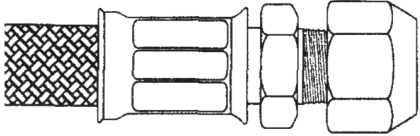
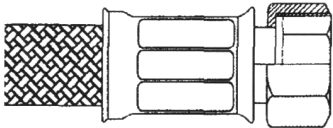
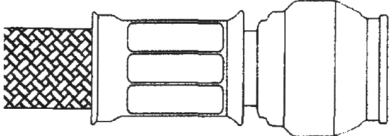
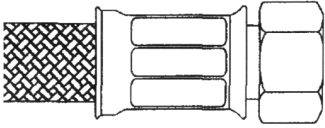
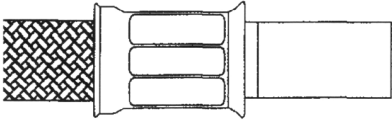
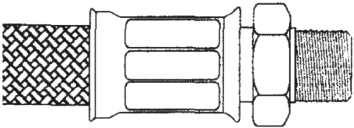
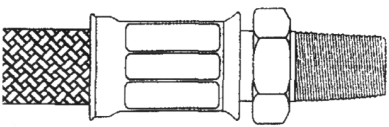
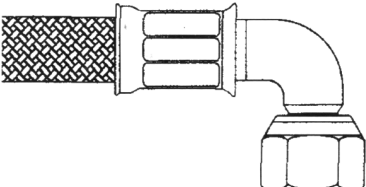

Typical Flexible Hose End Fitting Options (HVAC)

End Fitting Option	Description	Nominal Bore
	CF Compression Fitting c/w Brass Nut and Olive	13, 20, 25 1/2", 3/4", 1"
	SCF Swivel Female Nut c/w Cone Seat	13, 20, 25 1/2", 3/4", 1"
	PF Nickel Plated Brass 'PUSHFIT' c/w John Guest, Tectite OR other fittings	13 1/2"
	SFF Swivel Female Nut c/w Flat Face Seat	13, 20, 25 1/2", 3/4", 1
	SP 25mm Long Brass Stub pipe end To suit copper fittings	13, 20, 25 1/2", 3/4", 1
	PM Fixed Male c/w Parallel Thread	13, 20, 25 1/2", 3/4", 1
	TM Fixed Male c/w BSP Taper Male	13, 20, 25 1/2", 3/4", 1
	EF 90° Elbow with Swivel Female Nut c/w Flat Face Seat	13, 20, 25 1/2", 3/4", 1



Precision Engineering



Teddington Engineered Solutions

Unit 1 · Heol Cropin · Dafen Industrial Estate · Llanelli · SA14 8QW · UK
Tel: +44 (0)1554 744500 · Fax: +44 (0)1554 746435
Email: sales@tes.uk.com · Website: www.tes.uk.com